



Modeling HIV-HBV Co-infection Dynamics: Stochastic Differential Equations and Matlab Simulation with Euler-Maruyama Numerical Method

Mirgichan Khobochoa James ^{a*}, Cyrus Gitonga Ngari ^b,
Stephen Karanja ^a and Robert Muriungi ^a

^a Department of Mathematics, School of Pure and Applied Sciences, Meru University of Science and Technology, P.O.BOX 972-60200, Meru, Kenya.

^b Department of pure and Applied Sciences, Kirinyaga University, Kerugoya, Kenya.

Authors' contributions

This work was carried out in collaboration among all authors. All authors read and approved the final manuscript.

Article Information

DOI: <https://doi.org/10.9734/arjom/2024/v20i7811>

Open Peer Review History:

This journal follows the Advanced Open Peer Review policy. Identity of the Reviewers, Editor(s) and additional Reviewers, peer review comments, different versions of the manuscript, comments of the editors, etc are available here: <https://www.sdiarticle5.com/review-history/119562>

Original Research Article

Received: 05/05/2024

Accepted: 07/07/2024

Published: 11/07/2024

Abstract

HIV/AIDS and Hepatitis B co-infection complicates population dynamics and brings forth a wide range of clinical outcomes which makes it a difficult situation for public health. In particular designing treatment plans for the co-infection. A Stochastic Differential Equation (SDE) model is a special class of a stochastic model with continuous parameter space and continuous state space. Deterministic model lacks randomness while an

*Corresponding author: Email: kaks.mirgichan@gmail.com;

Cite as: James, Mirgichan Khobochoa, Cyrus Gitonga Ngari, Stephen Karanja, and Robert Muriungi. 2024. "Modeling HIV-HBV Co-Infection Dynamics: Stochastic Differential Equations and Matlab Simulation With Euler-Maruyama Numerical Method". Asian Research Journal of Mathematics 20 (7):49-69. <https://doi.org/10.9734/arjom/2024/v20i7811>.

SDE model accounts for randomness and uncertainties. In this study, an SDE model was formulated from an existing deterministic model to examine the variability of dynamic behavior. The analysis and numerical schemes were derived based on Euler-Maruyama SDE algorithms. The model utilized epidemiological insights with current developments in mathematical modeling approaches to represent the interaction between these two viruses. Matlab software was used to obtain SDE numerical results alongside the deterministic solution. Descriptive statistics of the sample paths indicated that the variability of infection outcomes oscillates around the deterministic trajectory. None of the sample paths are absorbed during the time steps. This shows the persistence of the co-infection in the population, in particular $I_{HB}(t)$. The variability of the infections ranges between 1.972 and 202.4, being lowest in AIDS infectives and highest in acute Hepatitis B infectives. An indication that variability cannot be ignored in designing control interventions of co-infections. These results provide new insights into the dynamics of co-infection through in-depth research and simulation, which helps to understand the inherent nature of deterministic model by incorporating the stochastic effects. These understanding will further help the policy makers in health sector to take care of the variability and uncertainty in designing treatment and management strategies.

Keywords: HIV-HBV co-infection; Stochastic Differential Equations (SDEs); Euler-Maruyama numerical scheme; Ito formula; Weiner process; Matlab software.

1 Introduction

Both Human Immunodeficiency Virus and Hepatitis B Virus are common viral infections that have substantial independent and combined negative effects on health outcomes around the world. Moreover, co-infection with both viruses presents unique challenges in designing treatment plans and management effort to curb this neglected co-infection, as their interactions accelerates the progression and spread of the mono-infections [1]. In co-infected individuals, the interaction between HIV and HBV can lead to complex and non-linear dynamics. Stochastic models allow incorporation of variability in viral load trajectories, providing insights on the emergence of viral mutants, drug resistance, and the likelihood of viral rebound following treatment interruptions [2]. The immune response plays a critical role in controlling viral infections, and its variability among individuals can significantly influence disease outcomes.

A stochastic process is described as a random process which evolves over time. It determines the probability distribution of a random variable. Stochastic processes are classified based on the random nature of parameter and state space; Discrete Parameter-Discrete state space, Discrete parameter-continuous state space, continuous parameter-Discrete state space and continuous parameter-continuous state space. Based on this categorization, we have Discrete-Time Markov Chain, Continuous Time Markov Chain, random walk, Poisson process, time series process and Brownian motion. An SDE is a special type of continuous time stochastic process. Various numerical schemes of solving stochastic model; Gillespie algorithms, Monte Carlo simulation, Euler-Maruyama and higher order numerical schemes such as Milstein method.

Stochastic models enable the exploration of how stochastic fluctuations in immune response parameters affect the progression of HIV-HBV co-infection and the efficacy of immune-based therapies [3]. Demographic factors such as population heterogeneity, contact patterns, and migration can introduce randomness into disease transmission dynamics. Stochastic models account for these factors, allowing for the assessment of the impact of demographic stochasticity on the spread of HIV and HBV within populations and the effectiveness of public health interventions [4] Although infectious disease dynamics have historically been studied using the classical deterministic models [5], these models frequently fall short of capturing the intrinsic heterogeneity and stochasticity of biological systems. Thus, stochastic mathematical modelling forms a basis and potential approach for understanding the intricate dynamics and interactions of this co-infection.

Few research have examined HBV co-infection in pregnant HIV-positive women. In addition, there is inadequate information on HIV-HBV co-infection from areas where the prevalence of chronic hepatitis B is high especially in remote settings of Sub-Saharan Africa. However, research conducted in Africa suggests that pregnant women with HIV are twice as likely to test positive for HBeAg and three times more likely to test positive for HBV DNA. High HBV DNA levels and HBeAg expression are linked to a greater chance of HBV transmission from a HIV-positive pregnant mother to her offspring [6].

Deterministic and stochastic models have been studied extensively in infectious disease modelling, but their application in HIV-HBV co-infection modelling has been limited due to difficulties in obtaining analytic results and the difficulty of analysing large populations. Many studies have shown that environmental variations have a huge impact on the development of an epidemic. Because person-to-person encounters are unpredictable, the nature of epidemic growth and spread for human illnesses is fundamentally random [7]. Additionally, the population is exposed to a continuous spectrum of disturbances [8]. As a result, the environment's unpredictability and fluctuation influence the epidemic's current status [8]. As a result, the environment's unpredictability and fluctuation influence the epidemic's current status [8]. Stochastic differential equation (SDEs) models is an appropriate way of modelling epidemics in many circumstances as used by Britton [9], Gray, A., et al. [10,11,12].

From a mathematical and biological point of view, there are several ways to incorporate random effects into epidemic models impacted by ambient white noise [2]. It has been shown by certain researchers that an environmentally perturbed system may be obtained by stochastically perturbing one or more system parameters using a white noise term. The general stochastic differential equation formulated in this study adopts the approach by Mao et al. [13,10]. This approach has been pursued in studies by Mandal, P. S., & Banerjee, M, [12] and assumes that the parameters involved in the model fluctuate around a mean value due to continuous fluctuations in the environment.

This paper aims to formulate, analyse and simulate a stochastic mathematical model to study the dynamic behavior of HIV-HBV co-infection at population scale. First, the model considered the deterministic model incorporating vaccination, viral load saturation function, treatment, infection levels and vertical transmission. We then convert deterministic model to a stochastic model using stochastic differential equations (SDEs) that incorporates random terms to better understand the random inherent nature and uncertainties in the dynamics of HIV-HBV co-infection outcomes and explains the complex interactions between HIV and HBV. It is therefore essential to comprehend the dynamics of HIV-HBV co-infection in order to design treatment approaches and lower the burden of HIV-HBV co-infection. In order to account for elements including host immune response variability, demographic stochasticity, and viral replication stochasticity, stochastic modelling techniques provide a more reasonable understanding of the dynamics of HIV-HBV co-infection. This model provides an insight on the dynamics of random perturbations such transmission rates, the possibility of infection and progression.

The paper is organized as follows; In section 2, the deterministic and stochastic model formulation is described and analyzed. Then, in section 3 we present the mathematical analysis of numerical model. In section 4, we validate the model numerically using secondary data. Obtained from the literature and finally, in section 5 we discuss the numerical results and followed by conclusion in section 6.

2 Model Formulation and Analysis

We first consider a deterministic model of HIV-HBV co-infection by dividing the general human population into three sub-populations; HIV sub-populations comprising of $I_H(t), V_H(t), A(t)$ and HBV sub-populations consisting of $V(t), I_B(t), I_{CB}(t), T_B(t), R(t)$ and co-infected sub-populations; $I_{HB}(t), I_{HCB}(t)$ and $T_{HB}(t)$. Beside these populations, we have the susceptible population, $S(t)$. The populations are clustered based on their infection status and are considered differentiable functions of time. The model variables and parameters are defined in Table 1 and Table 2 as follows;

Table 1. Description of model variables

Variable	Description
$S(t)$	Susceptible Individuals at time t
$I_H(t)$	Individuals infected with HIV with AIDS symptoms at time t
$A(t)$	Individuals with full blow AIDS symptoms at time t
$I_{HB}(t)$	Co-infected individuals with HIV and AHB at time t
$I_{HCB}(t)$	Co-infected individuals with HIV and CHB at time t
$T_{HB}(t)$	Co-infected individuals under HIV-HBV treatment at time t
$I_B(t)$	Individuals with AHB infection at time t

Variable	Description
$I_{CB}(t)$	Individuals with CHB infection at time t
$T_B(t)$	HBV infected individuals under treatment at time t
$R(t)$	Individuals who recover from HBV infection through treatment or natural immunity
$V(t)$	Vaccinated individuals against HBV
$V_H(t)$	HIV infected individuals vaccinated against HBV
$N(t)$	The total population at time t

Table 2. Description of model parameters

Parameter	Description
Λ	Force of infection
Π	Recruitment rate
b	Birth rate
β	Infection rate
μ	Natural mortality rate
δ_1	Mortality rate due to HIV/AIDS
δ_2	Induced death rate due to HBV infection
δ_3	Induced death rate due to HBV treatment
δ_4	Induced death rate due to HIV-HBV co infection
θ_1	Proportion of births infected with HIV
θ_2	Proportion of births infected with HBV
θ_3	Proportion of births vaccinated with HBV
θ_4	Proportion of births infected with HIV and vaccinated with HBV
θ_5	Proportion of susceptible births
ϵ_1	Efficacy of HIV drugs
ϵ_2	Efficacy of HBV drugs
σ	Treatment rate of HIV-HBV co-infected individuals
α	Hep B recovery rate due to natural immunity
ω	Drug/immunity waning rate
φ	Recovery rate of Hep B infected individuals due to treatment
τ	Treatment rate for mild Hep B to seek treatment
ϕ	Treatment rate of Acute Hep B infectious individuals
ψ	Progression rate of acute to chronic Hep B
γ	Progression rate of mild to chronic HIV-HBV co infection
D_H	HIV viral load saturation function
D_B	HBV viral load saturation function
Γ	Progression rate of Hep B vaccinated to HIV
ν	Progression rate of HIV vaccinated to HIV-HBV co infected
ρ	Proportion of HIV-HBV births

For the deterministic model, we make the following assumptions; both HIV and HBV infections are transmitted to mother to child during pregnancy, birth or breastfeeding, transmission or contact rates, recovery rate, progression rates are constant and both infections induces death alongside the natural death, individuals at AIDS stage and chronic stage of Hepatitis B don't recover in the course of the infection but individuals at acute stage of hepatitis B recover due to natural immunity and treatment. All individuals surge to natural death.

Based on these assumptions and definitions of model variables and parameters we construct a compartment structure for the populations as shown in Fig. 1.

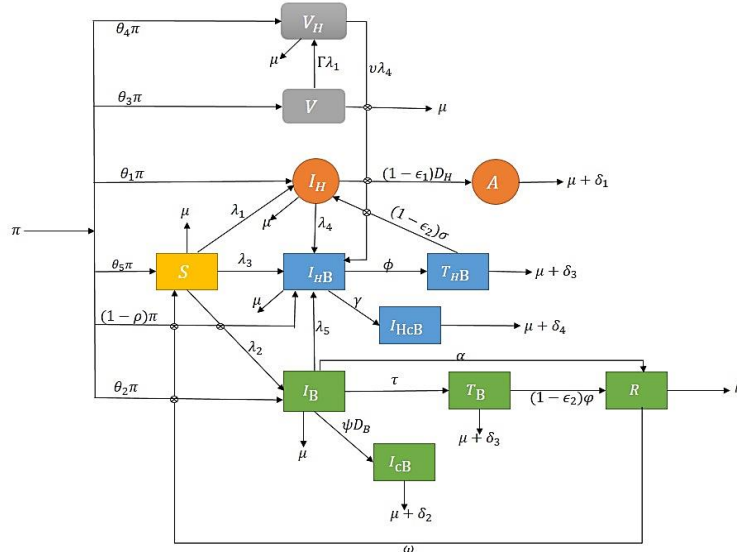

Fig. 1. HIV-HBV co-infection model flowchart

The deterministic model is governed by the following non-linear ordinary differential equations;

$$\frac{dS}{dt} = \theta_5\pi + (\lambda_1 + \lambda_2 + \lambda_3 + \mu)S + \omega R \quad (1)$$

$$\frac{dI_H}{dt} = \theta_1\pi + \lambda_1 S + (1 - \epsilon_2)\sigma T_{HB} - (\lambda_4 + \mu + (1 - \epsilon_1)D_H)I_H \quad (2)$$

$$\frac{dA}{dt} = (1 - \epsilon_1)D_H I_H - (\delta_1 + \mu)A \quad (3)$$

$$\frac{dI_{HB}}{dt} = (1 - \rho)\pi + \lambda_3 S + (I_H + v)\lambda_4 + \lambda_5 I_B - (\phi + \gamma + \mu)I_{HB} \quad (4)$$

$$\frac{dT_{HB}}{dt} = \phi I_{HB} - (\mu + \delta_3 + (1 - \epsilon_2)\sigma)T_{HB} \quad (5)$$

$$\frac{dI_{HcB}}{dt} = \gamma I_{HB} - (\mu + \delta_4)I_{HcB} \quad (6)$$

$$\frac{dV}{dt} = \theta_3\pi - (\mu + \Gamma\lambda_1)V \quad (7)$$

$$\frac{dV_H}{dt} = \theta_4\pi + \Gamma\lambda_1 V - (\mu + v\lambda_4)V_H \quad (8)$$

$$\frac{dI_B}{dt} = \theta_2\pi + \lambda_2 S - (\mu + \lambda_5 + \alpha + \tau + \psi D_B)I_B \quad (9)$$

$$\frac{dI_{cB}}{dt} = \psi D_B I_B - (\mu + \delta_2)I_{cB} \quad (10)$$

$$\frac{dT_B}{dt} = \tau I_B - (\mu + \delta_3 + (1 - \epsilon_2)\phi)T_B \quad (11)$$

$$\frac{dR}{dt} = \alpha I_B + (1 - \epsilon_2)\phi T_B - (\omega + \mu)R \quad (12)$$

Where;

$$\rho = \theta_1 + \theta_2 + \theta_3 + \theta_4 + \theta_5 ,$$

$$\lambda_1 = \frac{\beta_1(I_H + \eta_1 I_{HB} + \eta_2 I_{HCB} + \eta_3 A + \eta_4 T_{HB})}{N}, \text{ where } \eta_1 > \eta_2 > \eta_3 > \eta_4,$$

$$\lambda_2 = \beta_2(I_B + \chi_1 I_{CB} + \chi_2 I_{HB} + \chi_3 I_{HCB} + \chi_4 T_B + \chi_5 T_{HB}), \text{ where } \chi_1 > \chi_2 > \chi_3 > \chi_4,$$

$$\lambda_3 = \beta_3(I_{HB} + \Psi_1 I_{HCB} + \Psi_2 T_{HB}), \text{ where, } \Psi_1 > \Psi_2,$$

$$\lambda_4 = \beta_4(I_H + \Lambda_1 I_{HB} + \Lambda_2 I_{HCB} + \Lambda_3 A + \Lambda_4 T_{HB} + \Lambda_5 V_H), \text{ where } \Lambda_1 > \Lambda_2 > \Lambda_3 > \Lambda_4 > \Lambda_5 \text{ and } \lambda_5 = \beta_5(I_B + \Upsilon_1 I_{HB} + \Upsilon_2 I_{CB} + \Upsilon_3 I_{HCB} + \Upsilon_4 T_B + \Upsilon_5 T_{HB}), \text{ where } \Upsilon_1 > \Upsilon_2 > \Upsilon_3 > \Upsilon_4 > \Upsilon_5 \text{ and } \Gamma \leq 1 \text{ and } v \leq 1$$

and the total human population is defined by;

$$N(t) = S(t) + I_H(t) + A(t) + V(t) + V_H(t) + I_{HB}(t) + I_{HCB}(t) + T_{HB}(t) + I_B(t) + I_{CB}(t) + T_B(t) + R(t) \quad (13)$$

Formulation of SDEs from deterministic model involves inserting randomness or stochasticity into the ordinary differential equations (1) to (12) that explain the variability of the infections. Because it represents the intrinsic unpredictability in the transmission process, such as the probability of interactions between susceptible and infected people, randomness is critical to co-infection models. We incorporate randomness into the transmission rates of both HIV and HBV, considering factors such as the frequency and randomness of sexual contacts, sharing of needles or other drug paraphernalia, and perinatal transmission. We also consider the interactions between HIV and HBV infections, including the potential synergistic effects of co-infection on infection progression and transmission. Introducing stochastic terms to represent the effectiveness of treatment and control measures, such as ART for HIV and ART for HBV, as well as vaccination campaigns and behavioural interventions. We take into account for individual-level heterogeneity in contact patterns, susceptibility, and other factors that influence disease transmission, which may introduce additional stochasticity into the model. By formulating an SDE for an epidemic model, researchers can better capture the complex and dynamic nature of co-epidemics, including the effects of stochasticity on disease spread and the potential impact of interventions on epidemic dynamics (Allen, 2010). The study by Farnoosh and Parsamanesh [14] applied a general SDE to an SIS epidemic model with vaccination and immigration and the Ito's stochastic differential equations from transition probabilities technique, which is predicated on the diffusion process, was developed by (Allen, 2007) and Bonnet [15]. The generic form of the stochastic differential equation applied by Farnoosh and Parsamanesh, [14] and Allen (2007) is of the form;

$$dX = f(t, X(t))dt + g(t, X(t))dW(t) \quad (14)$$

where $X = [X_n]^T = \{S, I_H, A, I_{HB}, T_{HB}, I_{HCB}, V, V_H, I_B, I_{CB}, T_B, R\}^T$ is the vector of population of each compartment and $W(t) = [W_n(t)]^T$ is n-dimensional Wiener process. Vector f and 12×12 matrix g are drift or deterministic part and diffusion coefficients or stochastic terms, respectively. The functions f and g are defined as follows;

$$f(t, X(t)) = E(\Delta X / \Delta t) \text{ and } g(t, X(t)) = \sqrt{E[\Delta X (\Delta X)^T] / \Delta t} \quad (15)$$

According to Ditlevsen and Samson [16], continuous time processes are the focus of deterministic models, which are frequently represented by ODEs. These theories pre-assume that internal and deterministic mechanisms are the only ones driving the observable dynamics. Nevertheless, there will always be impacts on genuine biological systems that are poorly understood or impractical to formally represent. The analysis of the biological systems under study may suffer if these events are ignored in the modelling. As a result, there is a growing need to expand the deterministic models to include more intricate dynamical variations. Adding noise or random effects is one method of modelling these components. A system of SDEs is a logical extension of a deterministic differential equations model, in which pertinent parameters are either modelled as appropriate stochastic processes or additional stochastic processes are introduced to the driving system equations. This method makes the assumption that noise contributes to the dynamics.

Throughout this section, we assume that the states

$S(t), I_H(t), I_{HB}(t), A(t), I_B(t), I_{CB}(t), I_{HCB}(t), T_B(t), T_{HB}(t), V(t), V_H(t)$ and $R(t)$ are continuous random variables, that is,

$S(t), I_H(t), I_{HB}(t), A(t), I_B(t), I_{cB}(t), I_{HcB}(t), T_B(t), T_{HB}(t), V(t), V_H(t)$ and $R(t) \in [0, N]$, and that the time variable is continuous, $t \in [0, \infty)$.

and we denote;

$$\begin{aligned} \Delta S &= S(t + \Delta t) - S(t) \\ \Delta I_H &= I_H(t + \Delta t) - I_H(t) \\ \Delta A &= A(t + \Delta t) - A(t) \\ \Delta I_{HB} &= I_{HB}(t + \Delta t) - I_{HB}(t) \\ \Delta T_{HB} &= T_{HB}(t + \Delta t) - T_{HB}(t) \\ \Delta I_{HcB} &= I_{HcB}(t + \Delta t) - I_{HcB}(t) \\ \Delta V &= V(t + \Delta t) - V(t) \\ \Delta V_H &= V_H(t + \Delta t) - V_H(t) \\ \Delta I_B &= I_B(t + \Delta t) - I_B(t) \\ \Delta I_{cB} &= I_{cB}(t + \Delta t) - I_{cB}(t) \\ \Delta T_B &= T_B(t + \Delta t) - T_B(t) \\ \Delta R &= R(t + \Delta t) - R(t) \end{aligned}$$

In addition, we also assume that the change or transition of random variables $S(t), I_H(t), A(t), I_{HB}(t), T_{HB}(t), I_{HcB}(t), V(t), V_H(t), I_B(t), I_{cB}(t), T_B(t), R(t)$ is approximately normally distributed,

$$\begin{aligned} \Delta S(t) &\sim N(\mu(s)\Delta t, \sigma^2(s)\Delta t), \Delta I_H(t) \sim N(\mu(I_H)\Delta t, \sigma^2(I_H)\Delta t), \Delta A(t) \sim N(\mu(A)\Delta t, \sigma^2(A)\Delta t), \Delta I_{HB}(t) \sim \\ &N(\mu(I_{HB})\Delta t, \sigma^2(I_{HB})\Delta t), \Delta T_{HB}(t) \sim N(\mu(T_{HB})\Delta t, \sigma^2(T_{HB})\Delta t), \Delta I_{HcB}(t) \sim \\ &N(\mu(I_{HcB})\Delta t, \sigma^2(I_{HcB})\Delta t), \Delta V(t) \sim N(\mu(V)\Delta t, \sigma^2(V)\Delta t), \Delta V_H(t) \sim N(\mu(V_H)\Delta t, \sigma^2(V_H)\Delta t), \Delta I_B(t) \sim \\ &N(\mu(I_B)\Delta t, \sigma^2(I_B)\Delta t), \Delta I_{cB}(t) \sim N(\mu(I_{cB})\Delta t, \sigma^2(I_{cB})\Delta t), \Delta T_B(t) \sim N(\mu(T_B)\Delta t, \sigma^2(T_B)\Delta t), \Delta R(t) \sim \\ &N(\mu(R)\Delta t, \sigma^2(R)\Delta t) \end{aligned}$$

for small time intervals Δt .

We let X be the number of individuals in each class and ΔX the corresponding change in the number of individuals during time interval Δt ,

where vector $X = \{S, I_H, A, I_{HB}, T_{HB}, I_{HcB}, V, V_H, I_B, I_{cB}, T_B, R\}^T$ and

$$\Delta X = \{\Delta S, \Delta I_H, \Delta A, \Delta I_{HB}, \Delta T_{HB}, \Delta I_{HcB}, \Delta V, \Delta V_H, \Delta I_B, \Delta I_{cB}, \Delta T_B, \Delta R\}^T$$

be n-dimensional stochastic vectors. The possible changes or transitions from the deterministic model in Fig. 1 and their associated probabilities in a small time-interval Δt are computed as shown in the Table 4.

Table 3. Transition probabilities

Possible change of state	Probability	Event description
$\Delta X_1 = (1 \ 0 \ 0 \ 0 \ 0 \ 0 \ 0 \ 0 \ 0 \ 0 \ 0 \ 0 \ 0)$	$P_1 = \theta_5 \pi \Delta t$	Birth of a susceptible
$\Delta X_2 = (1 \ 0 \ 0 \ 0 \ 0 \ 0 \ 0 \ 0 \ 0 \ 0 \ 0 \ 0 \ -1)$	$P_2 = \omega R \Delta t$	Recovered becomes re-infected with HBV
$\Delta X_3 = (-1 \ 0 \ 0 \ 0 \ 0 \ 0 \ 0 \ 0 \ 0 \ 0 \ 0 \ 0 \ 0)$	$P_3 = \mu S \Delta t$	Susceptible dies a natural death
$\Delta X_4 = (-1 \ 1 \ 0 \ 0 \ 0 \ 0 \ 0 \ 0 \ 0 \ 0 \ 0 \ 0 \ 0)$	$P_4 = \lambda_1 S \Delta t$	Susceptible becomes infected with HIV
$\Delta X_5 = (-1 \ 0 \ 0 \ 0 \ 0 \ 0 \ 0 \ 0 \ 0 \ 1 \ 0 \ 0 \ 0)$	$P_5 = \lambda_2 S \Delta t$	Susceptible becomes infected with HBV
$\Delta X_6 = (-1 \ 0 \ 0 \ 1 \ 0 \ 0 \ 0 \ 0 \ 0 \ 0 \ 0 \ 0 \ 0)$	$P_6 = \lambda_3 S \Delta t$	Susceptible becomes co-infected with HIV-HBV
$\Delta X_7 = (0 \ 1 \ 0 \ 0 \ 0 \ 0 \ 0 \ 0 \ 0 \ 0 \ 0 \ 0 \ 0)$	$P_7 = \theta_1 \pi \Delta t$	Birth of infected HIV infants

Possible change of state	Probability	Event description
$\Delta X_8 = (0 \ 1 \ 0 \ 0 \ -1 \ 0 \ 0 \ 0 \ 0 \ 0 \ 0 \ 0 \ 0)$	$P_8 = (1 - \epsilon_2)\sigma T_{HB}\Delta t$	Treated Co-infected persons become infected with HIV
$\Delta X_9 = (0 \ -1 \ 1 \ 0 \ 0 \ 0 \ 0 \ 0 \ 0 \ 0 \ 0 \ 0 \ 0)$	$P_9 = (1 - \epsilon_1)D_H I_H \Delta t$	HIV infected persons progress to AIDS class
$\Delta X_{10} = (0 \ -1 \ 0 \ 0 \ 0 \ 0 \ 0 \ 0 \ 0 \ 0 \ 0 \ 0 \ 0)$	$P_{10} = \mu I_H \Delta t$	HIV infected dies natural death
$\Delta X_{11} = (0 \ 0 \ -1 \ 0 \ 0 \ 0 \ 0 \ 0 \ 0 \ 0 \ 0 \ 0 \ 0)$	$P_{11} = \delta_1 A \Delta t$	AIDS infected persons dies due to HIV infection
$\Delta X_{12} = (0 \ 0 \ -1 \ 0 \ 0 \ 0 \ 0 \ 0 \ 0 \ 0 \ 0 \ 0 \ 0)$	$P_{12} = \mu A \Delta t$	AIDS infected person dies naturally
$\Delta X_{13} = (0 \ 0 \ 0 \ 1 \ 0 \ 0 \ 0 \ 0 \ -1 \ 0 \ 0 \ 0 \ 0)$	$P_{13} = \lambda_5 I_B \Delta t$	AHB infected person becomes co-infected
$\Delta X_{14} = (0 \ 0 \ 0 \ 1 \ 0 \ 0 \ 0 \ 0 \ 0 \ 0 \ 0 \ 0 \ 0)$	$P_{14} = (1 - \rho)\pi \Delta t$	Birth of co-infected infants
$\Delta X_{15} = (0 \ 0 \ 0 \ 1 \ 0 \ 0 \ 0 \ -1 \ 0 \ 0 \ 0 \ 0 \ 0)$	$P_{15} = \nu \lambda_4 V_H \Delta t$	HIV positive-vaccinated with Hep B becomes co-infected
$\Delta X_{16} = (0 \ 0 \ 0 \ -1 \ 0 \ 0 \ 0 \ 0 \ 0 \ 0 \ 0 \ 0 \ 0)$	$P_{16} = \mu I_{HB} \Delta t$	HIV-HBV co-infected person dies natural death
$\Delta X_{17} = (0 \ 0 \ 0 \ -1 \ 1 \ 0 \ 0 \ 0 \ 0 \ 0 \ 0 \ 0 \ 0)$	$P_{17} = \phi I_{HB} \Delta t$	Co-infected seeks Hep B treatment
$\Delta X_{18} = (0 \ 0 \ 0 \ -1 \ 0 \ 1 \ 0 \ 0 \ 0 \ 0 \ 0 \ 0 \ 0)$	$P_{18} = \gamma I_{HB} \Delta t$	Co-infected becomes chronically infected with Hep B
$\Delta X_{19} = (0 \ 0 \ 0 \ 0 \ -1 \ 0 \ 0 \ 0 \ 0 \ 0 \ 0 \ 0 \ 0)$	$P_{19} = \mu T_{HB} \Delta t$	Treated co-infected person dies natural death
$\Delta X_{20} = (0 \ 0 \ 0 \ 0 \ -1 \ 0 \ 0 \ 0 \ 0 \ 0 \ 0 \ 0 \ 0)$	$P_{20} = \delta_3 T_{HB} \Delta t$	Treated co-infected person dies due to effects of Hep B treatment
$\Delta X_{21} = (0 \ 0 \ 0 \ 0 \ 0 \ -1 \ 0 \ 0 \ 0 \ 0 \ 0 \ 0 \ 0)$	$P_{21} = \mu I_{HCB} \Delta t$	HIV-CHB co-infected person dies naturally
$\Delta X_{22} = (0 \ 0 \ 0 \ 0 \ 0 \ -1 \ 0 \ 0 \ 0 \ 0 \ 0 \ 0 \ 0)$	$P_{22} = \delta_4 I_{HCB} \Delta t$	HIV-CHB co-infected person dies due to co-infection
$\Delta X_{23} = (0 \ 0 \ 0 \ 0 \ 0 \ 0 \ 0 \ 1 \ 0 \ 0 \ 0 \ 0 \ 0)$	$P_{23} = \theta_3 \pi \Delta t$	Birth of susceptible infants vaccinated with Hep B vaccine
$\Delta X_{24} = (0 \ 0 \ 0 \ 0 \ 0 \ 0 \ -1 \ 0 \ 0 \ 0 \ 0 \ 0 \ 0)$	$P_{24} = \mu V \Delta t$	HIV positive -vaccinated with Hep B vaccine dies natural death
$\Delta X_{25} = (0 \ 0 \ 0 \ 0 \ 0 \ 0 \ -1 \ 1 \ 0 \ 0 \ 0 \ 0 \ 0)$	$P_{25} = \Gamma \lambda_1 V \Delta t$	Hep B vaccinated person becomes infected with HIV
$\Delta X_{26} = (0 \ 0 \ 0 \ 0 \ 0 \ 0 \ 0 \ 0 \ 1 \ 0 \ 0 \ 0 \ 0)$	$P_{26} = \theta_4 \pi \Delta t$	HIV positive births vaccinated with Hep B vaccine
$\Delta X_{27} = (0 \ 0 \ 0 \ 0 \ 0 \ 0 \ 0 \ -1 \ 0 \ 0 \ 0 \ 0 \ 0)$	$P_{27} = \mu V_H \Delta t$	HIV-positive with Hep B vaccine dies natural death
$\Delta X_{28} = (0 \ 0 \ 0 \ 0 \ 0 \ 0 \ 0 \ 0 \ 0 \ 1 \ 0 \ 0 \ 0)$	$P_{28} = \theta_2 \pi \Delta t$	Births infected with Hep B
$\Delta X_{29} = (0 \ 0 \ 0 \ 0 \ 0 \ 0 \ 0 \ 0 \ -1 \ 1 \ 0 \ 0 \ 0)$	$P_{29} = \psi D_B I_B \Delta t$	Hep B infected person progresses to CHB
$\Delta X_{30} = (0 \ 0 \ 0 \ 0 \ 0 \ 0 \ 0 \ 0 \ -1 \ 0 \ 1 \ 0 \ 0)$	$P_{30} = \tau I_B \Delta t$	AHB infected person seeks treatment

Possible change of state	Probability	Event description
ΔX_{31} = (0 0 0 0 0 0 0 0 -1 0 0 1)	$P_{31} = \alpha I_B \Delta t$	AHB infected recovers by natural immunity
ΔX_{32} = (0 0 0 0 0 0 0 0 -1 0 0 0)	$P_{32} = \mu I_B \Delta t$	AHB infected person dies natural death
ΔX_{33} = (0 0 0 0 0 0 0 0 0 -1 0 0)	$P_{33} = \mu I_{CB} \Delta t$	CHB infected person dies natural death
ΔX_{34} = (0 0 0 0 0 0 0 0 0 -1 0 0)	$P_{34} = \delta_2 I_{CB} \Delta t$	CHB infected person dies due to Hep B infection
ΔX_{35} = (0 0 0 0 0 0 0 0 0 0 -1 1)	$P_{35} = (1 - \epsilon_2) \varphi T_B \Delta t$	Hep B treated person recovers
ΔX_{36} = (0 0 0 0 0 0 0 0 0 0 -1 0)	$P_{36} = \mu T_B \Delta t$	Treated Hep B infected person dies natural death
ΔX_{37} = (0 0 0 0 0 0 0 0 0 0 -1 0)	$P_{37} = \delta_3 T_B \Delta t$	Treated Hep B person dies due to treatment effects
ΔX_{38} = (0 0 0 0 0 0 0 0 0 0 0 -1)	$P_{38} = \mu R \Delta t$	Death of recovered individuals

In order to formulate the SDEs, we compute the expectation matrix, $E(\Delta X)$ and the covariance matrix, $Cov = E[\Delta X(\Delta X)^T]$ as follows;

$$E(\Delta X) = \sum_{i=1}^{38} P_i \Delta X_i = P_1 \Delta X_1 + P_2 \Delta X_2 + P_3 \Delta X_3 + P_4 \Delta X_4 + P_5 \Delta X_5 + P_6 \Delta X_6 + P_7 \Delta X_7 + P_8 \Delta X_8 + P_9 \Delta X_9 + P_{10} \Delta X_{10} + P_{11} \Delta X_{11} + P_{12} \Delta X_{12} + P_{13} \Delta X_{13} + P_{14} \Delta X_{14} + P_{15} \Delta X_{15} + P_{16} \Delta X_{16} + P_{17} \Delta X_{17} + P_{18} \Delta X_{18} + P_{19} \Delta X_{19} + P_{20} \Delta X_{20} + P_{21} \Delta X_{21} + P_{22} \Delta X_{22} + P_{23} \Delta X_{23} + P_{24} \Delta X_{24} + P_{25} \Delta X_{25} + P_{26} \Delta X_{26} + P_{27} \Delta X_{27} + P_{28} \Delta X_{28} + P_{29} \Delta X_{29} + P_{30} \Delta X_{30} + P_{31} \Delta X_{31} + P_{32} \Delta X_{32} + P_{33} \Delta X_{33} + P_{34} \Delta X_{34} + P_{35} \Delta X_{35} + P_{36} \Delta X_{36} + P_{37} \Delta X_{37} + P_{38} \Delta X_{38} \tag{16}$$

substituting for $P_i \Delta X_i$ and $\Delta X = \{\Delta S, \Delta I_H, \Delta A, \Delta I_{HB}, \Delta T_{HB}, \Delta I_{HCB}, \Delta V, \Delta V_H, \Delta I_B, \Delta I_{CB}, \Delta T_B, \Delta R\}^T$ into equation (16) we have

$$\frac{E(\Delta X)}{\Delta t} = f(X(t), t) = \begin{pmatrix} \theta_5 \pi + \omega R - \mu S - \lambda_1 S - \lambda_2 S - \lambda_3 S \\ \lambda_1 S + \theta_1 \pi - (1 - \epsilon_2) \sigma T_{HB} - (1 - \epsilon_1) D_H - \mu I_H \\ (1 - \epsilon_1) D_H I_H - \mu A - \delta_1 A \\ \lambda_5 I_B + (1 - \rho) \pi + \nu \lambda_4 V_H - \mu I_{HB} - \phi I_{HB} - \gamma I_{HB} \\ \phi I_{HB} - \mu T_{HB} - \delta_3 T_{HB} \\ \gamma I_{HB} - \mu I_{HCB} - \delta_4 I_{HCB} \\ \theta_3 \pi - \mu V - \Gamma \lambda_1 V \\ \theta_4 \pi - \mu V_H - \nu \lambda_4 V_H \\ \lambda_2 S + \theta_2 \pi - \alpha I_B - \mu I_B - \lambda_5 I_B - \psi D_B I_B \\ \psi D_B I_B - \mu I_{CB} - \delta_2 I_{CB} \\ \tau I_B - (1 - \epsilon_2) \varphi T_B - \mu T_B - \delta_3 T_B \\ \alpha I_B + (1 - \epsilon_2) \varphi T_B - \omega R - \mu R \end{pmatrix} \tag{17}$$

similarly, the covariance matrix is also computed as:

$$\frac{E[\Delta X(\Delta X)^T]}{\Delta t} = \sum_{i=1}^{38} P_i \Delta X(\Delta X)^T = V(X(t), t) = \begin{pmatrix} f_1 & -\lambda_1 S & 0 & 0 & 0 & 0 & 0 & 0 & 0 & 0 & 0 & -\omega R \\ -\lambda_1 S & f_2 & -(1 - \epsilon_1) D_H I_H & 0 & -(1 - \epsilon_2) \sigma T_{HB} & 0 & 0 & 0 & -(\lambda_1 S + \lambda_3 S - \theta_1 \pi) & 0 & 0 & 0 \\ 0 & -(1 - \epsilon_1) D_H I_H & f_3 & 0 & 0 & 0 & 0 & 0 & 0 & 0 & 0 & 0 \\ 0 & 0 & 0 & f_4 & -\phi I_{HB} & -\gamma I_{HB} & -\nu \lambda_4 V_H & 0 & -\lambda_5 I_B & 0 & 0 & 0 \\ 0 & -(1 - \epsilon_2) \sigma T_{HB} & 0 & -\phi I_{HB} & f_5 & 0 & 0 & 0 & 0 & 0 & 0 & 0 \\ 0 & 0 & 0 & -\gamma I_{HB} & 0 & f_6 & 0 & 0 & 0 & 0 & 0 & 0 \\ 0 & 0 & 0 & -\nu \lambda_4 V_H & 0 & \mu V + \Gamma \lambda_1 V & f_7 & 0 & 0 & 0 & 0 & 0 \\ 0 & 0 & 0 & 0 & 0 & -\Gamma \lambda_1 V & \Gamma \lambda_1 V & \theta_4 \pi + \mu V_H & 0 & 0 & 0 & 0 \\ -(\lambda_1 S + \lambda_3 S) & \theta_1 \pi & 0 & -\lambda_5 I_B & 0 & 0 & 0 & 0 & f_8 & -\psi D_B I_B & -\tau I_B & -\alpha I_B \\ 0 & 0 & 0 & 0 & 0 & 0 & 0 & 0 & -\psi D_B I_B & f_9 & 0 & 0 \\ 0 & 0 & 0 & 0 & 0 & 0 & 0 & 0 & -\tau I_B & 0 & 0 & -(1 - \epsilon_2) \varphi T_B \\ -\omega R & 0 & 0 & 0 & 0 & 0 & 0 & 0 & -\alpha I_B & 0 & -(1 - \epsilon_2) \varphi T_B & f_{11} \end{pmatrix} \tag{18}$$

Where

$$\begin{aligned}
 f_1 &= \theta_5\pi + \omega R + \mu S + \lambda_1 S + \lambda_2 S + \lambda_3 S \\
 f_2 &= \lambda_1 S + \theta_1\pi + (1 - \epsilon_2)\sigma T_{HB} + \mu I_H + (1 - \epsilon_1)D_H I_H \\
 f_3 &= (1 - \epsilon_1)D_H I_H + \delta_1 A + \mu A \\
 f_4 &= \lambda_5 I_B + (1 - \rho)\pi + v\lambda_4 V_H + \mu I_{HB} + \phi I_{HB} + \gamma I_{HB} \\
 f_5 &= (1 - \epsilon_2)\sigma T_{HB} + \phi I_{HB} + \mu T_{HB} + \delta_3 T_{HB} \\
 f_6 &= \gamma I_{HB} + \mu I_{HCB} + \delta_4 I_{HCB} \\
 f_7 &= v\lambda_4 V_H + \theta_3\pi - \Gamma\lambda_1 \\
 f_8 &= \lambda_1 S + \lambda_3 S + \theta_1\pi + \lambda_5 I_B + \theta_2\pi + \psi D_B I_B + \tau I_B + \alpha I_B + \mu I_B \\
 f_9 &= \psi D_B I_B + \mu I_{CB} + \delta_2 I_{CB} \\
 f_{10} &= \tau I_B + (1 - \epsilon_2)\varphi T_B + \mu T_B + \delta_3 T_B \\
 f_{11} &= \omega R + \alpha I_B + (1 - \epsilon_2)\varphi T_B + \mu R
 \end{aligned}$$

And thus, $g(X(t), t) = \sqrt{V}$, which represent the stochastic components of the transitions between compartments. These stochastic terms introduce randomness into the model, capturing the variability in the transmission, progression and recovery processes hence predicting the infection outcomes in future time, t. Applying equation (14) to the deterministic model, the following system of SDEs are derived;

$$dS(t) = (\theta_5\pi - (\lambda_1 + \lambda_2 + \lambda_3 + \mu)S + \omega R)dt + \sqrt{f_1}dW_1(t) - \sqrt{\lambda_1 S}dW_2(t) - \sqrt{\omega R}dW_3(t) \quad (19)$$

$$dI_H(t) = (\theta_1\pi + \lambda_1 S + (1 - \epsilon_2)\sigma T_{HB} - (\lambda_4 + \mu + (1 - \epsilon_1)D_H)I_H)dt - \sqrt{\lambda_1 S}dW_2(t) + \sqrt{f_2}dW_4(t) - \sqrt{(1 - \epsilon_1)D_H I_H}dW_5(t) - \sqrt{(1 - \epsilon_2)\sigma T_{HB}}dW_6(t) - \sqrt{\lambda_1 S + \lambda_3 S - \theta_1\pi}dW_7(t) \quad (20)$$

$$dA(t) = ((1 - \epsilon_1)D_H I_H - (\delta_1 + \mu)A)dt - \sqrt{(1 - \epsilon_1)D_H I_H}dW_5(t) + \sqrt{f_3}dW_8(t) \quad (21)$$

$$dI_{HB}(t) = ((1 - \rho)\pi + \lambda_3 S + v\lambda_4 V_H + \lambda_4 I_H + \lambda_5 I_B - (\phi + \gamma + \mu)I_{HB})dt + \sqrt{f_4}dW_9(t) - \sqrt{\phi I_{HB}}dW_{10}(t) - \sqrt{\gamma I_{HB}}dW_{11}(t) - \sqrt{v\lambda_4 V_H}dW_{12}(t) - \sqrt{\lambda_5 I_B}dW_{13}(t) \quad (22)$$

$$dT_{HB}(t) = (\phi I_{HB} - (\mu + \delta_3 + (1 - \epsilon_2)\sigma)T_{HB})dt - \sqrt{(1 - \epsilon_2)\sigma T_{HB}}dW_6(t) - \sqrt{\phi I_{HB}}dW_{10}(t) + \sqrt{f_5}dW_{14}(t) \quad (23)$$

$$dI_{HCB}(t) = (\gamma I_{HB} - (\mu + \delta_4)I_{HCB})dt - \sqrt{\gamma I_{HB}}dW_{11}(t) + \sqrt{f_6}dW_{15}(t) \quad (24)$$

$$dV(t) = (\theta_3\pi - (\mu + \Gamma\lambda_1)V)dt - \sqrt{v\lambda_4 V_H}dW_{12}(t) + \sqrt{\mu V + \Gamma\lambda_1 V}dW_{16}(t) + \sqrt{f_7}dW_{17}(t) \quad (25)$$

$$dV_H(t) = (\theta_4\pi + \Gamma\lambda_1 V - (\mu + v\lambda_4)V_H)dt - \sqrt{\Gamma\lambda_1 V}dW_{18}(t) + \sqrt{\Gamma\lambda_1 V}dW_{19}(t) + \sqrt{\theta_4\pi + \mu V_H}dW_{20}(t) \quad (26)$$

$$dI_B(t) = (\theta_2\pi + \lambda_2 S - (\mu + \lambda_5 + \alpha + \tau + \psi D_B)I_B)dt - \sqrt{\lambda_1 S + \lambda_3 S}dW_{21}(t) + \sqrt{\theta_1\pi}dW_{22}(t) - \sqrt{\lambda_5 I_B}dW_{13}(t) + \sqrt{f_8}dW_{23}(t) - \sqrt{\psi D_B I_B}dW_{24}(t) - \sqrt{\tau I_B}dW_{25}(t) - \sqrt{\alpha I_B}dW_{26}(t) \quad (27)$$

$$dI_{CB}(t) = (\psi D_B I_B - (\mu + \delta_2)I_{CB})dt - \sqrt{\psi D_B I_B}dW_{24}(t) + \sqrt{f_9}dW_{27}(t) \quad (28)$$

$$dT_B(t) = (\tau I_B - (\mu + \delta_3 + (1 - \epsilon_2)\varphi)T_B)dt - \sqrt{\tau I_B}dW_{25}(t) + \sqrt{f_{10}}dW_{28}(t) - \sqrt{(1 - \epsilon_2)\varphi T_B}dW_{29}(t) \quad (29)$$

$$dR(t) = (\alpha I_B + (1 - \epsilon_2)\varphi T_B - (\omega + \mu)R)dt - \sqrt{\omega R}dW_3(t) - \sqrt{\alpha I_B}dW_{26}(t) - \sqrt{(1 - \epsilon_2)\varphi T_B}dW_{29}(t) + \sqrt{f_{11}}dW_{30}(t) \quad (30)$$

Where,

$dW_1, dW_2, dW_3, dW_4, dW_5, dW_6, dW_7, dW_8, dW_9, dW_{10}, dW_{11}, dW_{12}, dW_{13}, dW_{14}, dW_{15}, dW_{16}, dW_{17}, dW_{18}, dW_{19}, dW_{20}, dW_{21}, dW_{22}, dW_{23}, dW_{24}, dW_{25}, dW_{26}, dW_{28}, dW_{29}, dW_{30}$ are the Wiener processes that denotes the random fluctuations over time, and there independent of each other.

3 Numerical Model

To complement the analytical results, we develop a numerical simulation framework using Euler-Maruyama scheme as explained by Bonnet, F. D. [15]. Euler-Maruyama numerical method is employed to capture stochastic fluctuations and assess the variability in model outcomes. The Euler-Maruyama is an analogue of the explicit Euler method for solving first order ODEs. The method is simple to implement and computationally efficient. It sets foundation for other numerical schemes for SDEs, such as Milstein and Runge-Kutta methods. It is first order accurate as it converges as Δt is reduced. By incorporating uncertainty in parameter estimates and initial conditions, the numerical model provides a comprehensive understanding of co-infection dynamics under real-world conditions. Solving the system of SDEs obtained above by direct integration techniques is not possible analytically, thus we solve numerically. Now to integrate equations (19) to (29) we state the Ito's lemma as follows;

Lemma 1: Suppose that the value of a variable X_t follows the Ito process, then the SDE of X_t is given by

$$dX_t = f(X, t) + G(X, t)dW \quad (31)$$

where dW is a Wiener process (Brownian motion) and f and G are functions of X and t .

Based on SDEs (19) to (29) and by applying the Ito's Lemma (30), the corresponding Euler-Maruyama numerical scheme is given by;

$$S(t + \Delta t) = S(t) + (\theta_5\pi - (\lambda_1 + \lambda_2 + \lambda_3 + \mu)S + \omega R)\Delta t + \sqrt{f_1}[W_1(t + \Delta t) - W_1(t)] - \sqrt{\lambda_1 S}[W_2(t + \Delta t) - W_2(t)] - \sqrt{\omega R}[W_3(t + \Delta t) - W_3(t)] \quad (32)$$

$$I_H(t + \Delta t) = I_H(t) + (\theta_1\pi + \lambda_1 S + (1 - \epsilon_2)\sigma T_{HB} - (\lambda_4 + \mu + (1 - \epsilon_1)D_H)I_H)\Delta t - \sqrt{\lambda_1 S}[W_2(t + \Delta t) - W_2(t)] + \sqrt{f_2}[W_4(t + \Delta t) - W_4(t)] - \sqrt{(1 - \epsilon_1)D_H I_H}[W_5(t + \Delta t) - W_5(t)] - \sqrt{(1 - \epsilon_2)\sigma T_{HB}}[W_6(t + \Delta t) - W_6(t)] - \sqrt{\lambda_1 S + \lambda_3 S - \theta_1\pi}[W_7(t + \Delta t) - W_7(t)] \quad (33)$$

$$A(t + \Delta t) = A(t) + ((1 - \epsilon_1)D_H I_H - (\delta_1 + \mu)A)\Delta t - \sqrt{(1 - \epsilon_1)D_H I_H}[W_5(t + \Delta t) - W_5(t)] + \sqrt{f_3}[W_8(t + \Delta t) - W_8(t)] \quad (34)$$

$$I_{HB}(t + \Delta t) = I_{HB}(t) + ((1 - \rho)\pi + \lambda_3 S + \nu\lambda_4 V_H + \lambda_4 I_H + \lambda_5 I_B - (\phi + \gamma + \mu)I_{HB})\Delta t + \sqrt{f_4}[W_9(t + \Delta t) - W_9(t)] - \sqrt{\phi I_{HB}}[W_{10}(t + \Delta t) - W_{10}(t)] - \sqrt{\gamma I_{HB}}[W_{11}(t + \Delta t) - W_{11}(t)] - \sqrt{\nu\lambda_4 V_H}[W_{12}(t + \Delta t) - W_{12}(t)] - \sqrt{\lambda_5 I_B}[W_{13}(t + \Delta t) - W_{13}(t)] \quad (35)$$

$$T_{HB}(t + \Delta t) = T_{HB}(t) + (\phi I_{HB} - (\mu + \delta_3 + (1 - \epsilon_2)\sigma)T_{HB})\Delta t - \sqrt{(1 - \epsilon_2)\sigma T_{HB}}[W_6(t + \Delta t) - W_6(t)] - \sqrt{\phi I_{HB}}[W_{10}(t + \Delta t) - W_{10}(t)] + \sqrt{f_5}[W_{14}(t + \Delta t) - W_{14}(t)] \quad (36)$$

$$I_{HCB}(t + \Delta t) = I_{HCB}(t) + (\gamma I_{HB} - (\mu + \delta_4)I_{HCB})\Delta t - \sqrt{\gamma I_{HB}}[W_{11}(t + \Delta t) - W_{11}(t)] + \sqrt{f_6}[W_{15}(t + \Delta t) - W_{15}(t)] \quad (37)$$

$$V(t + \Delta t) = V(t) + (\theta_3\pi - (\mu + \Gamma\lambda_1)V)\Delta t - \sqrt{\nu\lambda_4 V_H}[W_{12}(t + \Delta t) - W_{12}(t)] + \sqrt{\mu V + \Gamma\lambda_1 V}[W_{16}(t + \Delta t) - W_{16}(t)] + \sqrt{f_7}[W_{17}(t + \Delta t) - W_{17}(t)] \quad (38)$$

$$V_H(t + \Delta t) = V_H(t) + (\theta_4\pi + \Gamma\lambda_1 V - (\mu + \nu\lambda_4)V_H)\Delta t - \sqrt{\Gamma\lambda_1 V}[W_{18}(t + \Delta t) - W_{18}(t)] + \sqrt{\Gamma\lambda_1 V}[W_{19}(t + \Delta t) - W_{19}(t)] + \sqrt{\theta_4\pi + \mu V_H}[W_{20}(t + \Delta t) - W_{20}(t)] \quad (39)$$

$$I_B(t + \Delta t) = I_B(t) + (\theta_2\pi + \lambda_2 S - (\mu + \lambda_5 + \alpha + \tau + \psi D_B)I_B)\Delta t - \sqrt{\lambda_1 S + \lambda_3 S}[W_{21}(t + \Delta t) - W_{21}(t)] + \sqrt{\theta_1\pi}[W_{22}(t + \Delta t) - W_{22}(t)] - \sqrt{\lambda_5 I_B}[W_{13}(t + \Delta t) - W_{13}(t)] + \sqrt{f_8}[W_{23}(t + \Delta t) - W_{23}(t)]$$

$$W_{23}(t) - \sqrt{\psi D_B I_B} [W_{24}(t + \Delta t) - W_{24}(t)] - \sqrt{\tau I_B} [W_{25}(t + \Delta t) - W_{25}(t)] - \sqrt{\alpha I_B} [W_{26}(t + \Delta t) - W_{26}(t)] \tag{40}$$

$$I_{cB}(t) = I_{cB}(t) + (\psi D_B I_B - (\mu + \delta_2) I_{cB}) \Delta t - \sqrt{\psi D_B I_B} [W_{24}(t + \Delta t) - W_{24}(t)] + \sqrt{f_9} [W_{27}(t + \Delta t) - W_{27}(t)] \tag{41}$$

$$T_B(t + \Delta t) = T_B(t) + (\tau I_B - (\mu + \delta_3 + (1 - \epsilon_2)\varphi) T_B) \Delta t - \sqrt{\tau I_B} [W_{25}(t + \Delta t) - W_{25}(t)] + \sqrt{f_{10}} [W_{28}(t + \Delta t) - W_{28}(t)] - \sqrt{(1 - \epsilon_2)\varphi T_B} [W_{29}(t + \Delta t) - W_{29}(t)] \tag{42}$$

$$R(t + \Delta t) = R(t) + (\alpha I_B + (1 - \epsilon_2)\varphi T_B - (\omega + \mu) R) \Delta t - \sqrt{\omega R} [W_3(t + \Delta t) - W_3(t)] - \sqrt{\alpha I_B} [W_{26}(t + \Delta t) - W_{26}(t)] - \sqrt{(1 - \epsilon_2)\varphi T_B} [W_{29}(t + \Delta t) - W_{29}(t)] + \sqrt{f_{11}} [W_{30}(t + \Delta t) - W_{30}(t)] \tag{43}$$

4 Results and Discussion

In this section, we solve the SDEs by applying the Euler-Maruyama method in Matlab, which take into account the stochastic terms to approximate the system's behaviour over time. These simulations allow us to study the effects of stochasticity on co-infection dynamics and the uncertainty associated with model predictions. The same values of the parameters as in Table 4 are used but the initial conditions are estimated for small populations.

Table 4. Parameter values and initial conditions

Parameter	Nominal value/range	Source
N	1,196,275,773	https://www.worlddata.info/africa
S	1,617,203,400	https://www.ncbi.nlm.nih.gov
b	4.18 -37.1% (2021)	https://www.worlddata.info/africa
μ	13.1%	https://www.worlddata.info/africa/nigeria/index.php
μ	0.0246 (China)	Bacaër et al. [17]
δ_1	1.62% (2022)	https://www.who.int/news-room/fact-sheets/detail/hiv-aids
δ_1	0.7114	Zhang et al. (2011)
δ_2	0.28%-15%	WHO (2019)
δ_3	2.84 per 100persons/yr	Jia et al. (2022)
δ_4	42%	National Institutes of Health [18]
τ	10.5%	WHO (2019)
ω	2-24 weeks	https://www.hepb.org
I_H	39million	WHO (2022)
A	29.8million	UNAIDS (2022), https://www.unaids.org .
V_H	$\frac{2}{3}$ of people with HIV	Martin et al [19]
V	1 Billion people (2017)	https://www.hepb.org
I_B	1.704 Billion (2019)	https://www.hepb.org
I_{cB}	80million	Feigin et al [20]
I_{HB}	2.7 Million (1%)	WHO (2019), https://www.who.int/fact-sheets/hepatitis-b
I_{HCB}	8-10% of I_{HB}	Leumi et al. [21]
T_B	6.6%	WHO (2019)
T_{HB}	12-25% of I_{HB}	NIH (2020)
R	1.5336 Billion (90%)	https://www.hepb.org
λ_1	9.0%	Goliber [22]
λ_2	3.2-7.5%	WHO (2022)
λ_3	7.4-10%	WHO (2019), Thio [23]
λ_4	10%	NIH (2022)
λ_5	5-10%	Okocha et al. [24]
φ	2 -24 weeks	https://www.hepb.org

Parameter	Nominal value/range	Source
β_1	0.0257 - 0.0347	Nagelkerke et al. [25], Han et al. [26]
β_2	0.1-20%	Inoue and Tanaka [27]
β_3	10%	CDC, 2021
ψ	5-10%	Hyams [28]
γ	20-25%	Bodsworth et al. [29]
ϕ	17%	Hutin et al. [30]
β_4	5-20%	Singh et al. [31]
ν	8%	Mohareb and Kim [32]
D_H	2.3-5	Chen et al. [33], https://www.iapac.org
D_B	0.00008249	De Boer et al. [34], Whalley et al. [35]
α	94-98%	Organization et al. [36], Gastanaduy et al. [37]
Γ	22%	Allen et al. [38]
θ_1	85-90%	Frigati et al. [39]
θ_2	5.8-6%	Razavi-Shearer et al. [40]
θ_3	10-18%	Feldstein et al. [41], CDC (2022)
θ_4	15-45%	https://www.who.int/hepatitis/publications/global-hepatitis-report2017/en/
ϵ_1	60-80%	Koethe et al. [42]
ϵ_2	72-96%	Hadziyannis et al. [43]
ρ	0.7 to 11.6%	Landes et al. [44]
σ	80.7%	Pappoe et al. [45]

Both deterministic solution and sample paths of SDEs related to infectious classes $I_H(t)$, A , $I_B(t)$, $I_{CB}(t)$, $I_{HB}(t)$, and $I_{HCB}(t)$ are demonstrated in the following figures. Three sample paths of the SDEs are obtained to illustrate the range of variability of infections. The sample paths follow a property of the Wiener process that the sample paths are continuous but not differentiable.

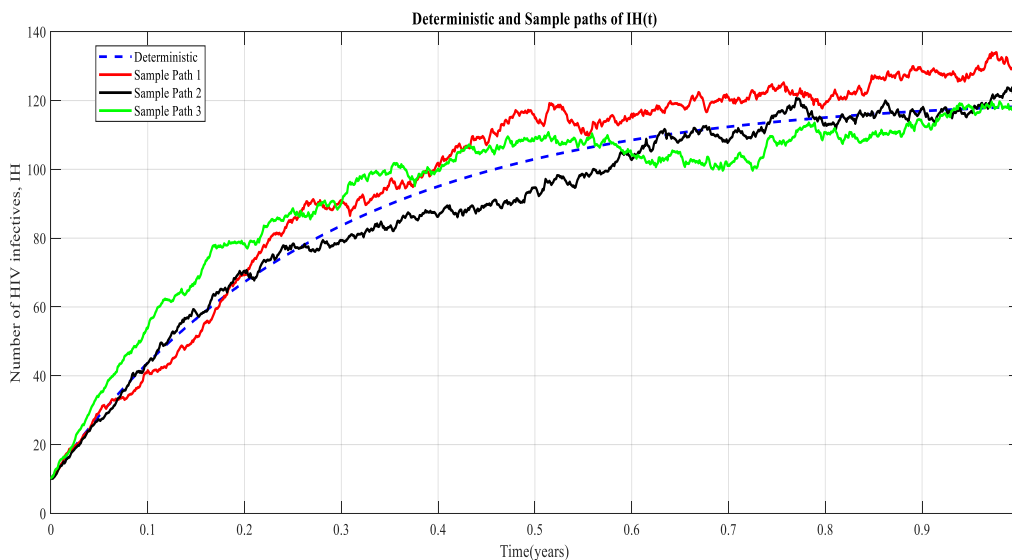

Fig. 2. Deterministic and Sample paths of $I_H(t)$

Fig. 2 above demonstrates the deterministic solution of $I_H(t)$ for a period of 1 year together with three sample paths of $I_H(t)$ for the same initial condition of $I_H(t)$, and parameter values remain constant. It is observed that the sample paths oscillate around the deterministic solution. The random fluctuations are as a result of stochastic processes dW_2, dW_4, dW_5, dW_6 and dW_7 . The range of volatility is shown by sample path 1 and 2. The variance between the deterministic and stochastic solution is marginally small. Sample 3 shows the smallest variability in the infections while sample path 1 shows the highest variability of infections. The data statistics for each of the sample is summarized in the table below;

Table 5. Data statistics for sample paths of IH(t)

Sample path	Ymin	Ymax	Mean	Range
S1	10	134	97.62	124
S2	10	123.8	88.93	113.8
S3	10	119.7	93.63	109.7
Deterministic	10	118.2	91.27	108.2

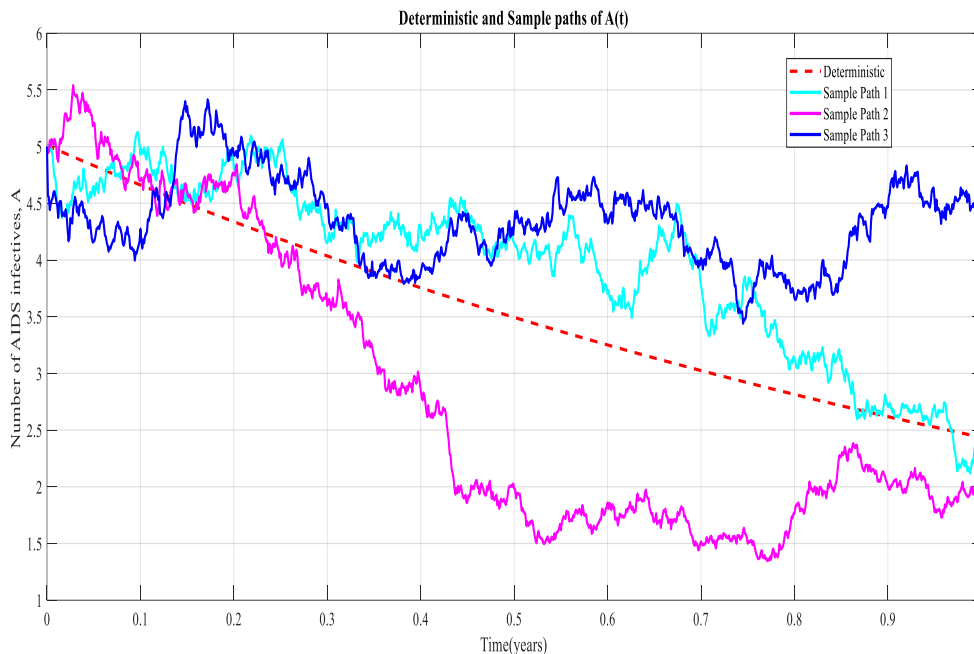

Fig. 3. Deterministic solution and sample paths of A(t)

Fig. 3 shows the deterministic and stochastic solutions of $A(t)$ for a period of 1 year. In deterministic solution, the AIDS infectives drops gradually following a smooth trajectory assuming no random fluctuations over time. This exponential decay is due to decrease in viral load as a result of consistent use of ARVS and efforts geared to reduce rate of new infections. Each of the sample paths of $A(t)$ shows large variations from deterministic trajectory due to changes in random shocks dW_5 and dW_8 . Sample path 2 shows the highest variability in infection outcomes while sample path 3 shows the lowest variations in infection outcomes as summarized in the table below;

Table 6. Data statistics for sample paths of A(t)

Sample path	Ymin	Ymax	Mean	Range
S1	2.12	5.128	3.965	3.008
S2	1.347	5.539	2.815	4.291
S3	3.442	5.414	4.345	1.972
Deterministic	2.437	5.006	3.57	2.57

Table 7. Data statistics of sample paths of IB(t)

Sample path	Ymin	Ymax	Mean	Range
S1	95.16	297.6	193.4	202.4
S2	62.8	172.1	119.7	109.3
S3	52.29	205.7	130.1	153.4
Deterministic	100	186.6	152.8	86.59

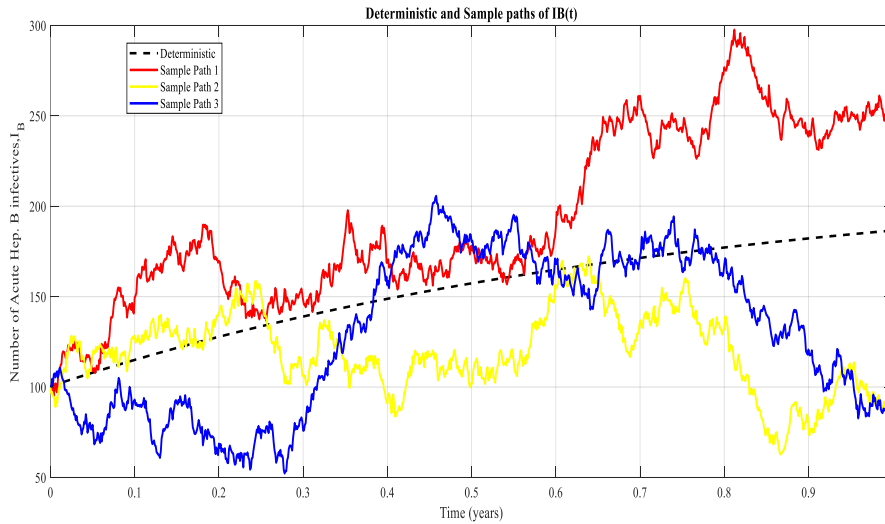

Fig. 4. Deterministic and sample paths of $I_B(t)$

Fig. 4 illustrates the dynamics of $I_B(t)$ over time in both deterministic and stochastic perspectives. In deterministic case, $I_B(t)$ increases over time, indicating a growing population of $I_B(t)$. This trend is attributed by rate of new infections exceeding the rate of acute Hep B infectives recovery or mortality. While in stochastic case, three sample paths display random fluctuations about the deterministic trajectory. Sample path 1 exhibit the largest variations in infections while sample path 2 shows the smallest variations in infections. These variations result from changes in Wiener processes dW_{13} , dW_{21} , dW_{22} , dW_{23} , dW_{24} , dW_{25} and dW_{26} . The descriptive statistics for each of the sample paths of $I_B(t)$ are tabulated as follows Table 7.

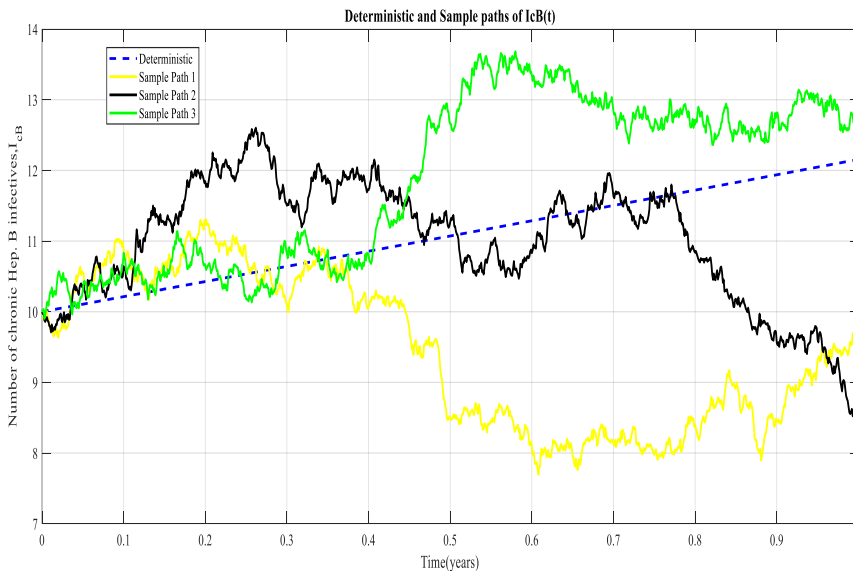

Fig. 5. Deterministic and sample paths of $I_{cB}(t)$

Fig. 5 depicts the deterministic and sample paths of $I_{cB}(t)$. The number of individuals with chronic viral hepatitis B increases with time due to increase in progression rate, compromised natural immunity, low treatment seeking behaviour of acute hepatitis B infectives or even low transmission rates of HIV-HBV co-infection. The Wiener processes dW_{24} and dW_{27} influences the random fluctuations of infections around the deterministic smooth trajectory. The magnitude and direction of random fluctuations vary with the sample paths with sample path 2 exhibiting the largest variation in infection and sample path 1 showing the smallest variations [46-48].

Table 8. Data statistics for sample paths of IcB(t)

Sample path	Ymin	Ymax	Mean	Range
S1	7.697	11.3	9.444	3.607
S2	8.525	12.6	11	4.074
S3	9.904	13.68	11.88	3.777
Deterministic	10	12.6	11.07	21.56

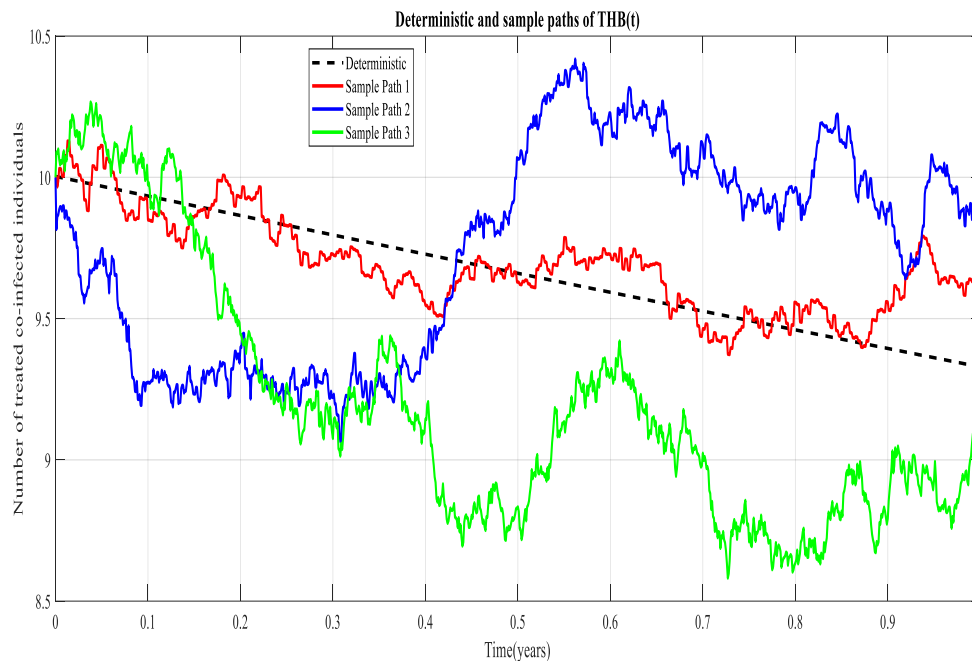

Fig. 6. Deterministic and sample paths of THB(t)

Fig. 6 illustrates the deterministic and stochastic sample paths of THB(t). In deterministic case, the number of treated co-infected individuals decreases with time as a result of induced deaths due to adverse effects of HIV-HBV drugs, HIV re-infection, natural deaths as opposed to low treatment rates of co-infected individuals. On the other hand, the number of treated co-infected individuals fluctuates about the deterministic path for each of the sample paths. This demonstrates that the solution paths are not converging or absorbing to infection free equilibrium point. The variability is visualized from the following data statistics for the solution paths. Sample path 3 gives the highest variability while sample path 1 gives the lowest [49-51].

Table 9. Data statistics for the solution paths of THB(t)

Solution path	Ymin	Ymax	Mean	Range
S1	9.373	10.13	9.689	0.7555
S2	9.064	10.42	9.742	1.354
S3	8.582	10.27	9.192	1.685
Deterministic	9.329	10	9.662	0.6737

Fig. 7 shows the deterministic and stochastic dynamic behaviour of $I_{HB}(t)$ with time. It is observed that $I_{HB}(t)$ grows linearly in deterministic case with time due to increase in transmission rates, progression rates and interactions between HIV and HBV infectives. The stochastic solution is demonstrated by three different sample paths with different realization of infection outcomes around the deterministic path. Sample path 2 shows the largest variability while sample path 3 exhibits the smallest variability of infection outcomes. The results of each sample path are as follows Table 10.

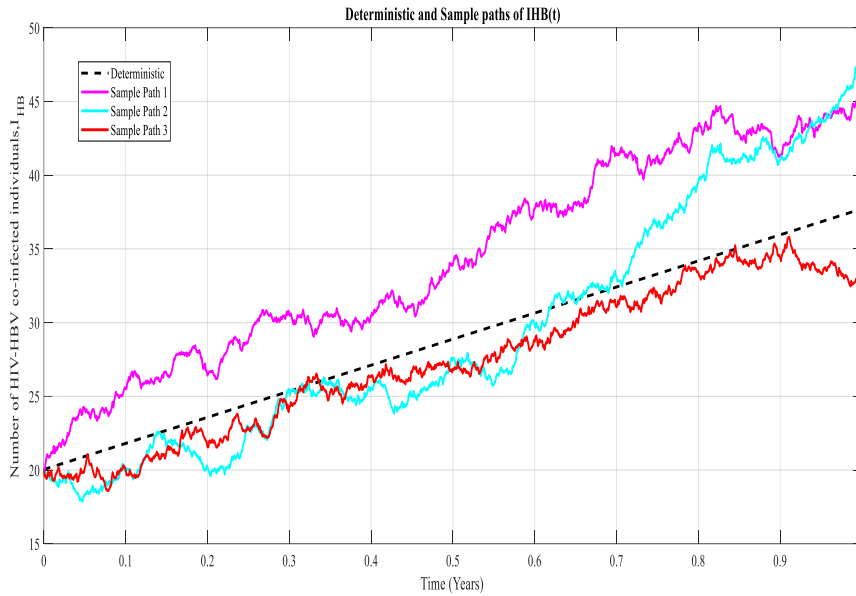

Fig. 7. Deterministic and Sample paths of $I_{HB}(t)$

Table 10. Data statistics for sample paths of $I_{HB}(t)$

Sample path	Ymin	Ymax	Mean	Range
S1	19.97	45.35	34.41	25.37
S2	17.88	47.46	29.36	29.58
S3	18.6	35.81	27.38	17.21
Deterministic	20	37.72	28.88	17.72

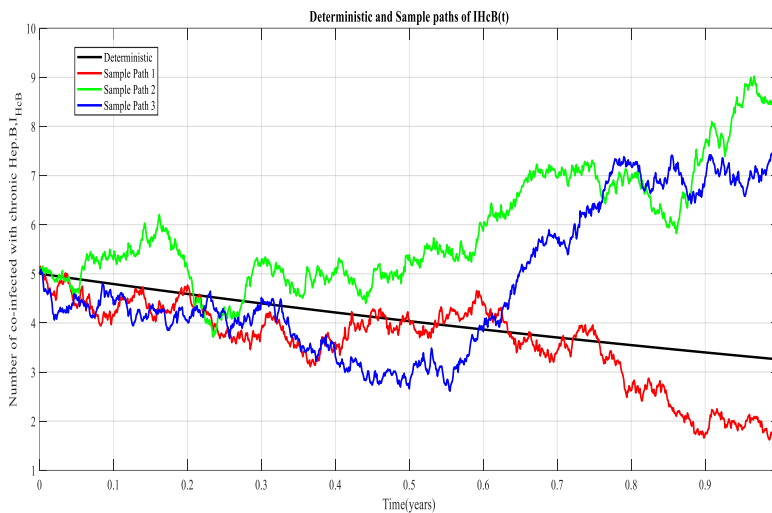

Fig. 8. Deterministic and Sample Paths of $I_{HCB}(t)$

In Fig. 8, it is observed that the number of $I_{HCB}(t)$ infectives declines with time in the deterministic case. This trend is due to slow rate of new HIV and HBV infections as well as high treatment rates for HIV-HBV co-infected individuals. In stochastic solution, the magnitude and direction of random fluctuations vary among the sample paths representing the Wiener processes dW_{11} and dW_{15} . Sample path 3 shows the highest variability of infections while sample path 1 gives the lowest as displayed in the table below.

Table 11. Data statistics for sample paths of IHCB(t)

Sample path	Ymin	Ymax	Mean	Range
S1	1.625	5.147	3.604	3.522
S2	3.716	9.018	5.89	5.303
S3	2.614	7.971	4.82	5.357
Deterministic	3.256	5	4.067	1.744

5 Conclusion

In this paper, we converted the deterministic model to a stochastic model by formulating SDEs. The drift and volatility coefficients are derived from the expectation matrix and covariance matrix of the transition matrices of the possible stochastic processes. Numerical simulations using the Euler-Maruyama method showed that stochastic processes introduce variability into the dynamics of infectious disease dynamics, leading to deviations from the deterministic solution. The sample paths oscillate around the deterministic trajectory over time, a characteristic behaviour due to the interplay between deterministic and stochastic forces. Sample paths showed varying levels of variability in each case ranging between 1.972 and 202.4. From the numerical simulations of the solution paths, it is evident that there exist variations in the mean and range of infection dynamics. This confirms that there is variability in infection outcomes in all the infectious classes contributing to co-infection.

Despite the presence of stochastic processes, the variance between deterministic and stochastic solutions is close, suggesting that the overall trend remains consistent with the deterministic solution. Thus, to mitigate HIV-HBV co-infection randomness in transmission rates should be taken into consideration in designing treatment and management strategies. This provides insights to policy health makers and implementers. Hence, key considerations should be made on implementing both clinical and non-clinical control interventions. Especially formulating and implementing national policy for immunization schedule for viral hepatitis as well as vaccinating infants born by HIV mothers. Screening of susceptible population is also key as a potential intervention to identify vulnerable populations. The health practitioners should consider to diagnose all patients seeking any medical attention. Further, the government through the Ministry of Health should conduct regular campaigns on HIV-HBV coinfection and give appropriate guidelines. These variability in infection outcomes further implies that demographic patterns, contact or interaction patterns among other factors are key components to consider to make better decisions in designing optimal control measures.

Disclaimer (Artificial Intelligence)

Author(s) hereby declare that NO generative AI technologies such as Large Language Models (ChatGPT, COPILOT, etc) and text-to-image generators have been used during the writing or editing of manuscripts.

The simulation results in this article cannot be generalized for other epidemic models. Matlab codes for the numerical simulation is available with the corresponding author on request.

Competing Interests

The authors have declared that no competing interests exist.

References

- [1]. Body A, Hoy JF, Cheng AC, Giles ML. Body A. Incident hepatitis B infection subsequent to the diagnosis of HIV infection in a Melbourne cohort: missed opportunities for prevention. *Sexual Health*. 2013;11(1):5-10.
- [2]. Minayev P, Ferguson N. Incorporating demographic stochasticity into multi-strain epidemic models: Application to influenza A. *Journal of the Royal Society Interface*. 2009;6(40):989-996.

- [3]. Ferguson NM, Donnelly CA, Anderson RM. Transmission dynamics and epidemiology of dengue: insights from age-stratified sero-prevalence surveys. *Philosophical Transactions of the Royal Society of London. Series B: Biological Sciences*. 1999;3
- [4]. Blower SM, Gershengorn HB, Grant RM. A tale of two futures: HIV and antiretroviral therapy in San Francisco. *Science*. 2000;287(5453):650-654.
- [5]. Kermack W, McKendrick M. Contributions to the mathematical theory of epidemics. 1. In: *Proc. R. Soc. Edinb. A*. 1927;700-721.
- [6]. Hoffmann CJ, Thio CL. Clinical implications of HIV and hepatitis B co-infection in Asia and Africa. *The Lancet Infectious Diseases*. 2007;7(6):402-409.
- [7]. Spence S. Stochastic epidemic models for emerging diseases (Doctoral dissertation, University of Nottingham); 2008.
- [8]. Beddington JR, May RM. Harvesting natural populations in a randomly fluctuating environment. *Science*. 1977;197(4302):463-465.
- [9]. Britton T. Stochastic epidemic models: A survey. *Mathematical Biosciences*. 2010;225(1):24-35.
- [10]. Gray A, Greenhalgh D, Hu L, Mao X, Pan J. A stochastic differential equation SIS epidemic model. *SIAM Journal on Applied Mathematics*. 2011;71(3):876-902.
- [11]. Ji C, Jiang D, Shi N. A note on a predator-prey model with modified Leslie-Gower and Holling-type II schemes with stochastic perturbation. *Journal of Mathematical Analysis and Applications*. 2011;377(1):435-440.
- [12]. Mandal PS, Banerjee M. Stochastic persistence and stationary distribution in a Holling-Tanner type prey-predator model. *Statistical Mechanics and its Applications*. 2012;391(4):1216-1233.
- [13]. Mao X, Sabanis S, Renshaw E. Asymptotic behaviour of the stochastic Lotka-Volterra model. *Journal of Mathematical Analysis and Applications*. 2003;287(1):141-156.
- [14]. Farnoosh, Rahman, Parsamanesh, Mahmood. "Stochastic differential equation systems for an SIS epidemic model with vaccination and immigration". *Communications in Statistics-Theory and Methods*. 2017;(17):8723--8736.
- [15]. Bonnet FD. Option pricing using path integrals (Doctoral dissertation); 2010.
- [16]. Ditlevsen, Susanne, Samson, Adeline. Introduction to stochastic models in biology. *Stochastic biomathematical models: With applications to neuronal modeling*. 2013;3--35.
- [17]. Bacaër Nicolas, Abdurahman Xamxinur, Ye Jianli. Modeling the HIV/AIDS epidemic among injecting drug users and sex workers in Kunming, China. *Bulletin of Mathematical Biology*. 2006;68(3):525--550.
- [18]. National Institutes et al. HIV and opportunistic infections, coinfections, and conditions; 2022.
- [19]. Martins Saulo, Livramento Andréa do, Andrigueti, Michelle, Kretzer, Iara Fabricia, Machado, Marcos José, Spada, Celso, Tr. Vaccination coverage and immunity against hepatitis B among HIV-infected patients in South Brazil. *Brazilian Journal of Infectious Diseases*. 2015;19:181--186.
- [20]. Feigin, Valery L, Stark, Benjamin A, Johnson, Catherine Owens, Roth, Gregory A, Bisignano, Catherine, Abady, Gdiom Gebreheat A. Global, regional, and national burden of stroke and its risk factors, 1990--2019: a systematic analysis for the Global Burden. *The Lancet Neurology*. 2021;20(10):795--820.

- [21]. Leumi, Steve, Bigna, Jean Joel, Amougou, Marie A, Ngouo, Anderson, Nyaga, Ulrich Flore, Noubiap, Jean Jacques. Global burden of hepatitis B infection in people living with human immunodeficiency virus: A systematic review and meta-analysis. *Clinical Infectious Diseases*. 2020;71(11):2799--2806.
- [22]. Goliber Thomas. The status of the HIV/AIDS epidemic in Sub-Saharan Africa. Population Reference Bureau; 2002.
- [23]. Thio Chloe L. Hepatitis B and human immunodeficiency virus coinfection. LWW; 2009.
- [24]. Okocha EC, Oguejiofor OC, Odenigbo CU, Okonkwo UC, Asomugha L. Prevalence of hepatitis B surface antigen seropositivity among HIV-infected and non-infected individuals in Nnewi, Nigeria. *Nigerian Medical Journal: Journal of the Nigeria Medical Association*. 2012;53(4):249.
- [25]. Nagelkerke, Nico JD, De Vlas, Sake J, Jha, Prabhat, Luo, Ma, Plummer, Francis A, Kaul Rupert. Heterogeneity in host HIV susceptibility as a potential contributor to recent HIV prevalence declines in Africa. *AIDS (London, England)*. 2009;23(1):125.
- [26]. Han L, Lou J, Ruan Y, Shao Y. The analysis of the HIV/AIDS mathematical model for the injection drug use population. *J Biomath*. 2008;23(3):429-434.
- [27]. Inoue Takako, Tanaka Yasuhito. Hepatitis B virus and its sexually transmitted infection-an update. *Microbial cell*. 2016;3(9):420.
- [28]. Hyams Kenneth C. Risks of chronicity following acute hepatitis B virus infection: A review. *Clinical Infectious Diseases*. 1995;20(4):992-1000.
- [29]. Bodsworth Neil J, Cooper, David A, Donovan Basil. The influence of human immunodeficiency virus type 1 infection on the development of the hepatitis B virus carrier state. *Journal of Infectious Diseases*. 1991;163(5):1138-1140.
- [30]. Hutin Yvan, Nasrullah Muazzam, Easterbrook Philippa, Dongmo Nguimfack, Boniface, Burrone Esteban, Averhoff, Francisco. Access to treatment for hepatitis B virus infection worldwide. *American Journal of Transplantation*. 2018;2595-2598.
- [31]. Singh Kasha P, Crane Megan, Audsley Jennifer, Avihingsanon, Anchalee, Sasadeusz Joe, Lewin Sharon R. HIV-hepatitis B virus coinfection: Epidemiology, pathogenesis, and treatment. *Aids*. 2017;31(15):2035--2052.
- [32]. Mohareb Amir M, Kim Arthur Y. Hepatitis B vaccination in people living with HIV at first you don't succeed, try again. *JAMA Network Open*. 2021;4(8):e2121281-e2121281.
- [33]. Chen Can, Xiao Yanni et al. Modeling saturated diagnosis and vaccination in reducing HIV/AIDS infection. in *Abstract and Applied Analysis*. 2014;2014.
- [34]. De Boer, Rob J, Oprea, Mihaela, Antia, Rustom, Murali-Krishna, Kaja, Ahmed, Rafi, Perelson, Alan S, Recruitment times, proliferation, and apoptosis rates during the CD8+ T-cell response to lymphocytic choriomeningitis virus. *Journal of Virology*. 2001;75(22):10663-10669.
- [35]. Whalley Simon A, Murray, John M, Brown, Dave, Webster, George JM, Emery, Vincent C, Dusheiko, Geoffrey M, Perelson Alan S. Kinetics of acute hepatitis B virus infection in humans. *The Journal of Experimental Medicine*. 2001;193(7):847--854.
- [36]. Organization, World Health et al. Training modules on Hepatitis B and C screening, diagnosis and treatment; 2020.
- [37]. Gastanaduy, Paul A, Redd, Susan B, Clemmons, Nakia S, Lee, Adria D, Hickman, Carole J, Rota, Paul A, Patel Manisha. Manual for the surveillance of vaccine-preventable diseases. Center for Disease Control and Prevention.; 2019.
Available:<https://www.cdc.gov/vaccines/pubs/surv-manual/chpt07-measles.html>.

- [38]. Allen Kahtonna, Mesner, Octavio, Ganesan, Anuradha, OâBryan, Thomas A, Deiss, Robert G, Agan, Brian K, Okulicz, Jason F. Association between hepatitis B vaccine antibody response and CD4 reconstitution after initiation of combination antiretroviral. *BMC Infectious Diseases*. 2015;15:1-6.
- [39]. Frigati Lisa J, Ameyan Wole, Cotton Mark F, Gregson Celia L, Hoare Jacqueline, Jao Jennifer, Majonga, Edith D, Myer Land. Chronic comorbidities in children and adolescents with perinatally acquired HIV infection in sub-Saharan Africa in the era of a The Lancet Child & Adolescent Health. 2020;4(9):688--698.
- [40]. Razavi-Shearer Devin, Gamkrelidze Ivane, Nguyen Mindie H, Chen Ding-Shinn, Van Damme Pierre, Abbas Zaigham, Abdulla Mahe. Global prevalence, treatment, and prevention of hepatitis B virus infection in 2016: A modelling study. *The Lancet Gastroenterology & Hepatology*. 2018;3(6):383-403.
- [41]. Feldstein Leora R, Mariat, Stephanie, Gacic-Dobo, Marta, Diallo, Mamadou S, Conklin, Laura M, and Wallace, Aaron S. Global routine vaccination coverage. *Morbidity and Mortality Weekly Report*. 2016;66(45):1252.
- [42]. Koethe John R, Lagathu, Claire, Lake, Jordan E, Domingo, Pere, Calmy, Alexandra, Falutz, Julian, Brown, Todd T, Capeau, Ja. HIV and antiretroviral therapy-related fat alterations. *Nature Reviews Disease Primers*. 2020;6(1):48.
- [43]. Hadziyannis, Stephanos J, Papatheodoridis, George V, Dimou, Evangelini, Laras, Andreas, Papaioannou, Christos. Efficacy of long-term lamivudine monotherapy in patients with hepatitis B e antigen--negative chronic hepatitis B. *Hepatology*. 2000;32(4):847--851.
- [44]. Landes, Megan, Newell, M-L, Barlow, Patricia, Fiore, Simona, Malyuta, Ruslan, Martinelli, Pasquale, Posokhova, Svetlana, Savasi. Hepatitis B or hepatitis C coinfection in HIV-infected pregnant women in Europe. *HIV Medicine*. 2008;9(7):526-534.
- [45]. Pappoe Faustina, Hagan, Charles Kofi Oheneba, Obiri-Yeboah Dorcas, Nsiah Paul. Sero-prevalence of hepatitis B and C viral infections in Ghanaian HIV positive cohort: A consideration for their health care. *BMC Infectious Diseases*. 2019;19(1):1-8.
- [46]. Allen Linda JS. A primer on stochastic epidemic models: Formulation, numerical simulation, and analysis. *Infectious Disease Modelling*. 2017;2(2):128--142.
- [47]. Dennis B. Allee effects in stochastic populations. *Oikos*. 2002;96(3):389-401.
- [48]. Durrett R. Stochastic spatial models. *SIAM Review*. 1999;41(4):677-718.
- [49]. Mao X. Stochastic differential equations and applications. Elsevier; 2007.
- [50]. Mollison D. Dependence of epidemic and population velocities on basic parameters. *Mathematical Biosciences*. 1991;107(2):255-287.
- [51]. Zhu C, Yin G. On competitive Lotka–Volterra model in random environments. *Journal of Mathematical Analysis and Applications*. 2009;357(1):154-170.

Disclaimer/Publisher’s Note: The statements, opinions and data contained in all publications are solely those of the individual author(s) and contributor(s) and not of the publisher and/or the editor(s). This publisher and/or the editor(s) disclaim responsibility for any injury to people or property resulting from any ideas, methods, instructions or products referred to in the content.

© Copyright (2024): Author(s). The licensee is the journal publisher. This is an Open Access article distributed under the terms of the Creative Commons Attribution License (<http://creativecommons.org/licenses/by/4.0>), which permits unrestricted use, distribution, and reproduction in any medium, provided the original work is properly cited.

Peer-review history:

The peer review history for this paper can be accessed here (Please copy paste the total link in your browser address bar)

<https://www.sdiarticle5.com/review-history/119562>