



# Robustness Analysis of a Closed-loop Controller for a Robot Manipulator in Real Environments

Emmanuel Chukwudi Agbaraji<sup>1\*</sup>

<sup>1</sup>Department of Electronics and Computer Engineering, Nnamdi Azikiwe University, Awka, Nigeria.

## Author's contribution

The sole author designed, analyzed and interpreted and prepared the manuscript.

## Article Information

DOI: 10.9734/PSIJ/2015/18253

### Editor(s):

- (1) Wynand Verwoerd, Lincoln University, Christchurch, New Zealand.  
(2) Stefano Moretti, School of Physics & Astronomy, University of Southampton, UK.

### Reviewers:

- (1) Fabian Andres Lara Molina, Federal Technological University of Paraná, Brazil.  
(2) Jianjun Ni, Hohai University, China.  
(3) Raquel Dormido Canto, National University of Distance Education, Spain.  
(4) Ravi Narayan, Thapar University, Patiala, India.

Complete Peer review History: <http://sciencedomain.org/review-history/11910>

Review Article

Received 11<sup>th</sup> April 2015  
Accepted 9<sup>th</sup> September 2015  
Published 19<sup>th</sup> October 2015

## ABSTRACT

The need to design a robot manipulator that can complete tasks satisfactorily in the presence of significant uncertainties brought about the continued advance research in robust system design. This paper focuses on the robustness analysis of a closed-loop controller for robot manipulator in real environment. The neglect of wide range of uncertainties and failure to study the fundamental behavioral responses during design stage of a control system result to the system failure in real environments. The robustness analysis studies these essential behavioral responses of a controlled system considering the significant uncertainties that exist in real environment in order to design a robust controlled system. It was concluded that the robot manipulator controlled system can only achieve robustness when it can maintain low sensitivities and zero steady state error, stable over the range of parameter variations and its performance continues to meet the specifications of the designer in the presence of wide set of uncertainties. Robustness and optimization of the robot manipulator can be achieved using closed-loop control technique. Bode plot can be used to ascertain the performance and robustness behavior of the controlled system in frequency domain. The disturbance rejection and disturbance rejection settling time describe how well and fast the controlled system can overcome disturbances.

\*Corresponding author: Email: [wattchux@yahoo.com](mailto:wattchux@yahoo.com), [wattchux@gmail.com](mailto:wattchux@gmail.com);

**Keywords:** Closed-loop control; controller; control system; disturbance rejection; robot manipulator; robustness analysis.

## 1. INTRODUCTION

Robotics and automation are taking dominance in the industrial process. The robot arm position control system or the robot manipulator can be in different forms and shapes and are applied in different places for numerous types of operations. The rigid robots are dynamic systems that have multiple applications in industry, including welding, painting, and assembly of electronic parts [1]. Robot manipulators can be deployed to operate in some places where human life may be at risk or in processes that require a very high production rate or accuracy. Due to the level of uncertainties encountered by the robot systems in some environments, the sole goal of designing a working robot becomes inadequate. Many robot manipulators are being designed and built, but the question becomes “is the robot manipulator system resilient, robust, fault tolerant or optimal”. Some robot manipulators can fail in performance due to the level of disturbances they encounter in their areas of operations especially when the uncertainties in the real environments are neglected during the design phase. The numerous applications and the expected performance level of the robot manipulators lead to the development of analytical tools to ensure better performance of the electromechanical systems. The main aim of advance research in the control engineering should be to study the control systems considering the real environments with significant disturbances and designing a controller that can help the systems to achieve desired performance even in the presence of the disturbances.

Control system theory can be said to be the basis of system performance improvement. It is also the foundation of automation and robotics. The control system can be implemented in two different ways: open-loop and closed loop control techniques. The open-loop control contains a controller and the plant without a feedback subsystem hence; it lacks the knowledge of its output and any possible variation due to plant uncertainties. Closed-loop control systems contain a controller, plant and a feedback subsystem hence; it measures the output of the controlled system and compares it with the reference input (or desired output) to produce an error signal. A Controller is the subsystem that generates the input to the plant or process [2]. A

controller with a feedback subsystem can be referred to as a closed-loop controller. Feedback control systems are widely used in manufacturing, mining, automobile, oil exploration and other hardware applications. In response to increased demands for increased efficiency and reliability, these control systems are required to deliver more accurate and better overall performance in the presence of difficult and changing operating conditions.

Robust control deals explicitly with uncertainty in its approach to controller design, aiming to achieve robust performance and/or stability in the presence of modeling errors and disturbances. Controllers designed using *robust control* methods tend to be able to cope with differences between the true system and the nominal model used for design. Some of the examples of modern robust control techniques include H-infinity loop-shaping, Sliding Mode Control (SMC) and artificial intelligence (AI) based control. Application of AI technique to some of these modern control techniques has been used to achieve more precise and satisfactory results in controller designs. Siqueira and Terra [3] developed a neural network-based H<sub>∞</sub> controller for fully actuated and underactuated cooperative manipulators. Their proposed controller uses neural networks to approximate only the uncertain parameters associated with an H<sub>∞</sub> performance index which contains position and squeeze force errors. Nogueira et al. [4] carried out an experimental investigation on adaptive robust controller designs applied to constrained manipulators. From their results, the steady state error in the fuzzy system-based controllers tend to be smaller than those based on neural networks, however, the both AI methods performed desirably well under disturbances. Corradini et al. [5] developed a discrete Time SMC of Robotic Manipulators and their results show good trajectory tracking performance as well as robustness in the presence of model inaccuracies, disturbances and payload perturbations. Considering the application of robust controllers of robotic manipulators, Lara-Molina et al. [6] worked on robust generalized predictive control of the Orthoglide robot. Their experimental results show the benefits of the robustified predictive control strategy on the dynamical performance of the Orthoglide robot in terms of tracking accuracy, disturbance rejection, attenuation of noise acting on the control signal

and parameter variation without increasing the computational complexity.

In order to design control systems to meet the needs of improved performance and robustness when controlling complicated processes and for optimal operations in real environments, control engineers should use new design tools and better control theory. In a survey on the controller design methods for robot manipulators in harsh environments [7], it was discovered that most design methods did not consider robustness of the control system especially in terms of the behavior of disturbance rejection trajectory. Most methods of analyses based more on the performance in terms of Rise Time ( $T_r$ ), Settling Time ( $T_s$ ) and Percentage Overshoot (%OS), but it is not enough considering the fact that the control system would operate in real environments with different levels of uncertainties. Hence, to solve this problem the robustness analysis is suggested to be a basic requirement in control systems design. This will involve the basic understanding of the control system behavior and the use of mathematical techniques such as Bode plot to determine the stability and robustness, the disturbance rejection response to determine steady state error. These analyses are now made easier by the use of software tool such as MATLAB.

## 2. CLOSED-LOOP CONTROL

The two major types of control that can be used in the design of a robot manipulator are namely open-loop and closed-loop control. The closed-loop control as shown in Fig. 1 is a more popular technique applied in most control systems design. Most conventional robotic arms depend on sensory feedback to perform their tasks [8]. Some people believe that the closed-loop is the

only method of control that can be implemented in the design of robot arm. However, some recent robot designs applied open-loop control based on feed-forward technique. Sano et al. [9] investigated on an open-loop control, which does not need the joint angles and velocities, for two degree of freedom (2DOF) robot manipulators with antagonistic biarticular muscles which are passing over adjacent two joints and acting on the both joints simultaneously. Their approach was inspired by the fact that humans do not measure the joint angles and velocities explicitly. Plooj et al. [8] designed an open Loop stable control in repetitive manipulation tasks. In their design, the robotic arm can perform repetitive tasks without the need for feedback (i.e. the control is open loop). But, in order to help the robot manipulator to have knowledge of its output performance is to feed back a measure of its output into the system so that the system can adjust itself to reduce the possible error (i.e. the difference between actual output and desired output) by the help of a controller, thereby performs optimally. This process is termed optimization of the control system performance. Since the open-loop control lacks feedback element, hence, optimization becomes much impossible. As a result, an open-loop control for robot manipulator will lack robustness since robustness is achieved through the feedback of the measured output into the system.

Closed-loop control is generally used in the design of robot manipulators as applied in [10-17]. This technique can be said to be inspired by human body behavior. The human body has numerous sensory elements (sensors) that can sense temperature, texture, and even pressure and by the help of the eyes, sight is also achieved. These sensors measure the actual

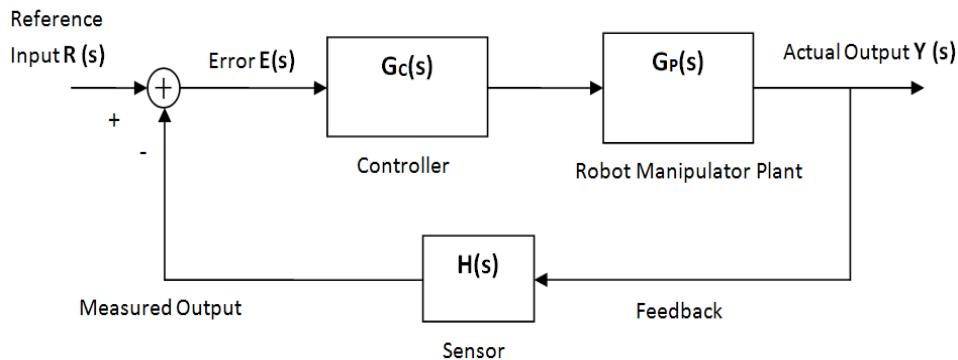

Fig. 1. A block diagram of a closed-loop control system

output and feed back the signal to the brain (controller) which computes the difference between the actual output and desired output and generates a motor action. This closed-loop action helps the body to adjust to situations to perform healthily. The robot manipulator can be optimized to achieve robustness through a closed-loop controller technique as shown in Fig. 1. The term plant refers to the system under control and can consist of mechanical / electrical / sensor / other aspects. In this case it is a robot manipulator or robot arm position control system. The transfer function of robot manipulator plant  $G_p(s)$  is given as:

$$G_p = \frac{K_T}{JL_ms^3 + (R_mJ + BL_ms)s^2 + (K_TK_m + R_mB)s}$$

Where;

- $R_m$  = armature- winding resistance in ohm
- $L_m$  = armature - winding inductance in Henry
- $K_m$  = back emf constant in volt / (rad/sec)
- $K_T$  = motor torque constant in N.m/A
- $J$  = moment of inertia of motor and robot arm in  $kg^2 m / rad$
- $B$  = viscous - friction coefficient of motor and robot arm in N.m/rad /sec

### 3. ROBUST CLOSED- LOOP CONTROLLER DESIGN METHODOLOGY

Physical system such as the robot manipulator and the real environment in which it operates cannot be modeled precisely, may change in an unpredictable manner and may be subject to significant disturbances. The design of a control system in the presence of significant uncertainty requires the designer to seek for a robust system [18]. The main targets in designing control systems are stability, good disturbance rejection, and small tracking error [19,20]. The controller helps to achieve these design targets of the control system [7]. The goal of robust control system design is to retain assurances of system performance in spite of model inaccuracies and changes. A system is robust when the system has acceptable changes in performance due to model changes or inaccuracies [18]. The disturbance rejection is used to test the

robustness [21] of a robot arm control system. Robustness design considers a wide range of possible disturbances, faults or uncertainties in a real environment. Robust control for robot manipulators is a typical control scheme to achieve good tracking performance in the presence of model uncertainties such as an unknown payload and unmodeled friction [22,15]. Uncertainties to be frequently encountered in robot manipulators working under an unstructured environment or handling variable payloads must be taken into account to solve the tracking problem of robot manipulators. Spong [23] suggested a robust control strategy for robot manipulators with uncertainty bounds to depend only on the inertia parameters of the robot. However, robustness design should consider both parametric and structural or non parametric uncertainties. These uncertainties may be due to unknown payloads and or unmodeled friction such as joint friction.

The recent advances in robust control design methodology aim to achieve stability robustness and performance robustness in the presence of significant uncertainties. Such advances include output-feedback  $H_\infty$  controllers, SMC, AI based controllers etc. A robust controlled manipulator should exhibit the desired performance despite the presence of significant process uncertainty and this can be achieved using closed-loop control technique. The Proportional-Integral-Derivative (PID) controller has proven efficient in the design of robust control systems. The PID is a feedback control technique which can be adjusted or tuned to achieve the desired performance specifications of the robot manipulator. Various tuning methods of the PID controller for a robot manipulator were reviewed in [7]. The objective of the controller design is to choose the parameters  $K_p$ ,  $K_i$ , and  $K_D$  to meet desired specifications and have desirable robustness properties. The software tool method with automatic PID tuner was suggested to be easier and provides the necessary parameters to design a robust controller. Fig. 2a shows the internal structure of PID controller  $G_c(s)$  and Fig. 2b shows the PID controller in a closed-loop controlled system. The PID controller transfer function has the form:

$$G_c(s) = \frac{U(s)}{E(s)} = K_p \left( 1 + \frac{1}{T_i s} + T_D s \right) = K_p + \frac{K_i}{s} + K_D s = \frac{K_D s^2 + K_p s + K_i}{s}$$

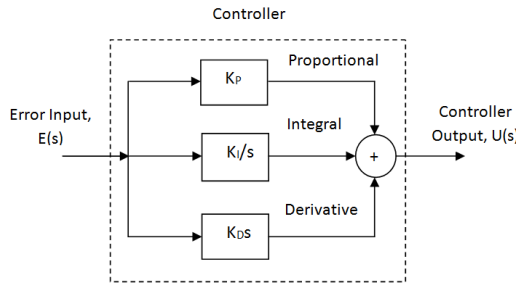

Fig. 2a. PID controller internal structure

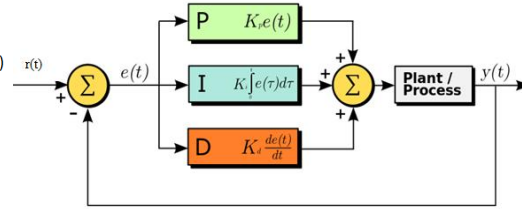

Fig. 2b. PID controller in a closed-loop system

Robotic manipulators are highly nonlinear dynamic systems with unmodelled dynamics and uncertainties [24], and the design of ideal controller for such systems has become a challenge to the control engineers because the robotic manipulators are expected to perform satisfactorily in real environments. Designing a controller that can achieve high robustness will help to address the effects of unmodelled dynamics and uncertainties.

A control system is robust when it maintains the following features over a range of changes in its parametric and structural properties:

1. It has low sensitivities and zero steady state error
2. It is stable over the range of parameter variations and
3. The performance continues to meet the specifications in the presence of a set of changes in the system parameters

#### 4. ROBUSTNESS ANALYSIS

This involves the examination of control system design to understand the system behavior considering the uncertainties and changes the system may face in real environment. The areas of interest include the reduction of sensitivity to model uncertainties, disturbance rejection, measurement noise attenuation, steady state errors and transient response characteristics [18], also disturbance rejection settling time or sensitivity graph settling time. This will involve the use of some mathematical models such as Bode plot and reference tracking to analyze the system for stability, performance and robustness. The transient responds is the output response of the system as a function of time and it must be adjusted (through the controller) to be satisfactory in order to achieve desired goal of the control system design.

#### 4.1 Sensitivity/Tracking Error Signal

System sensitivity is the ratio of the percentage change in the controlled system transfer function to the percentage change of the plant transfer function. The sensitivity of a control system to parameter variations is very important. A main advantage of a closed-loop feedback system is its ability to reduce the system's sensitivity. Robustness is the low sensitivity of the controlled system to effects that are not considered in the analysis and design phase such as disturbances, measurement noise and unmodeled dynamics. The system should be able to withstand these uncertainty effects when performing its operations. The relationship between the complementary sensitivity function  $C(s)$  and sensitivity function  $S(s)$  of the closed-loop controlled robot manipulator is as follows:

$$C(s) = \frac{G_C(s)G_P(s)}{1 + G_C(s)G_P(s)}$$

$$S(s) = \frac{1}{1 + G_C(s)G_P(s)}$$

$$C(s) + S(s) = 1$$

The tracking error of the closed-loop control system can be related to the reference input  $R(s)$  and the actual output  $Y(s)$  of the controlled system as follows:

$$E(s) = Y(s) - R(s)$$

One of the objectives in designing a control system is that the controlled system's output should exactly and instantaneously reproduce its input [18]. This implies that  $Y(s) = R(s)$ . Hence, the transfer function should tend to unity and error  $E(s)$  will tend to zero.

$$T(s) = \frac{Y(s)}{R(s)} = 1$$

$$E(s) = Y(s) - R(s) = 0$$

At this point  $T(s) - E(s) = 1$

$$Y(s) = \frac{G_C(s)G_P(s)}{1 + G_C(s)G_P(s)}R(s) + \frac{G(s)}{1 + G_C(s)G_P(s)}T_d(s) - \frac{G_C(s)G_P(s)}{1 + G_C(s)G_P(s)}N(s)$$

$$E(s) = \frac{1}{1 + G_C(s)G_P(s)}R(s) - \frac{G(s)}{1 + G_C(s)G_P(s)}T_d(s) + \frac{G_C(s)G_P(s)}{1 + G_C(s)G_P(s)}N(s)$$

$$L(s) = G_C(s)G_P(s)$$

The function  $L(s)$ , is known as the loop gain and it plays a fundamental role in control system design and analysis. In terms of the loop gain  $L(s)$ , tracking error  $E(s)$  function becomes:

$$E(s) = \frac{1}{1 + L(s)}R(s) - \frac{G(s)}{1 + L(s)}T_d(s) + \frac{L(s)}{1 + L(s)}N(s)$$

The magnitude of the loop gain  $L(s)$  can be described by considering the magnitude  $|L(j\omega)|$  over the range of frequencies,  $\omega$ , of interest. Considering the tracking error, for a given  $G_P(s)$ , to reduce the influence of the disturbance  $T_d(s)$ , on the tracking error  $E(s)$ ,  $L(s)$  should be made large over the range of frequencies that characterize the disturbances. In that way, the transfer function  $G_C(s)/(1+G_C(s)G_P(s))$  will be small and it implies that the controller  $G_C(s)$  should be designed to have a large magnitude. Conversely, to attenuate the measurement noise,  $N(s)$ , and reduce the influence on the tracking error,  $L(s)$  should be made small over the range of frequencies that characterize the measurement noise. Hence, the transfer function  $G_C G_P/(1+G_C(s)G_P(s))$  will be small, thereby reducing the influence of  $N(s)$  and this implies that the controller  $G_C(s)$  should be designed to have small magnitude. The conflict that exists in making the controller  $G_C(s)$  to be large to reject disturbances and at the same time making  $G_C(s)$  to be small to attenuate measurement noise can be addressed in the design phase by making the loop gain,  $L(s) = G_C(s)G_P(s)$ , to be large at low frequencies (associated with frequency range of disturbances), and making  $L(s)$  small at high frequencies (associated with measurement noise). Fortunately, this design complication is addressed easily by the use of software tools such as MATLAB/SIMULINK, implementing automatic tuning method of PID controller design method.

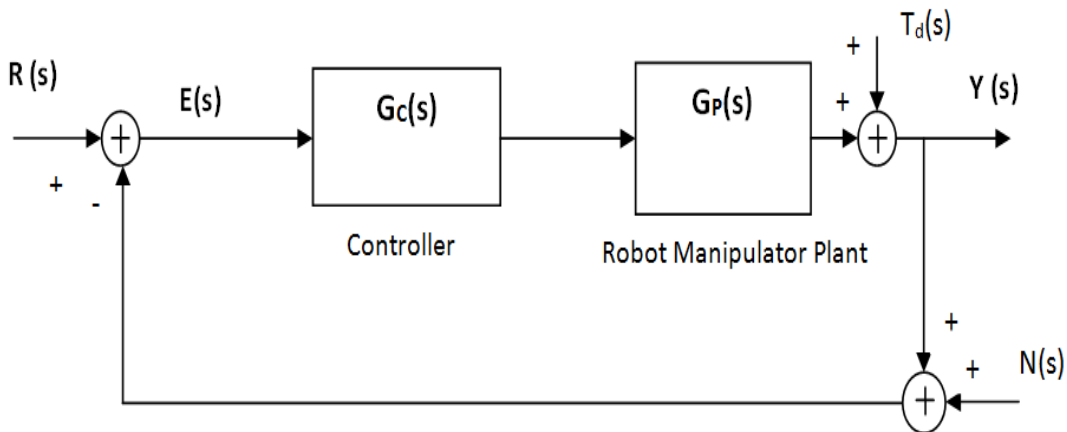

Fig. 3. Control system with disturbance and noise inputs in real environment

The goal of the design should be to minimize the sensitivity and steady state error to zero in order to achieve robustness and optimization of the controlled system. The system should continue to maintain a zero steady state error in the presence of significant disturbance. The disturbance rejection settling time shows how fast the controlled system can reject disturbances and it should be at the minimum value for the system to achieve robustness at the presence of wide range of uncertainties. Figs. 4a, 4b and 4c illustrate the step disturbance rejection response of a closed-loop controlled robot manipulator with different controller gains using SIMULINK PID tuner tool. It can be seen that the final value of the steady state error is zero in Figs. 4a and 4b for systems A and B, therefore the systems can be robust but the disturbance rejection settling time is higher in Fig. 4a with 384sec than in Fig. 4b with 61sec. The system with lower disturbance rejection settling time will cancel the effect of disturbance faster and becomes more resilient. However, the steady state error final value in Fig. 4c for system C is not zero therefore, the system is not robust

despite that other performance parameters such as  $T_r$ ,  $T_s$  and %OS may be within desired values.

### 4.2 Stability Robustness

In control system engineering, it is imperative to study the stability of control systems in order to be equipped with the behavior of the system under both steady and transient conditions [2]. Stability is that characteristic of a system defined by a natural response that decays to zero as time approaches infinity. In order to investigate system stability, Root-locus, Bode and Nyquist plots are applied [25]. Nichols charts is also used to study the stability of control systems. Bode plot is used in this work to demonstrate stability of the robot manipulator because it shows more clearly the stability margins: gain margin and phase margin. It also illustrates the stability robustness behavior of the system in the magnitude graph. Stability robustness must be achieved in the design of a controlled system to withstand unforeseen significant uncertainties neglected during the design phase of the robot manipulator.

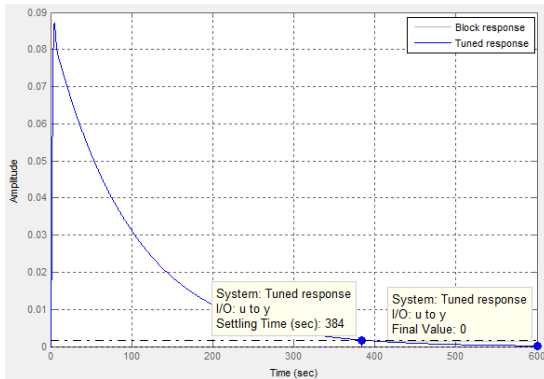

Fig. 4a. Step disturbance rejection of A

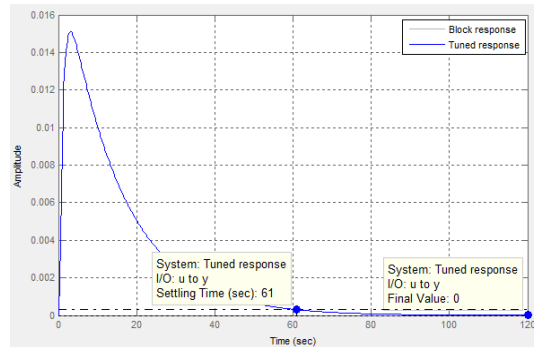

Fig. 4b. Step disturbance rejection of B

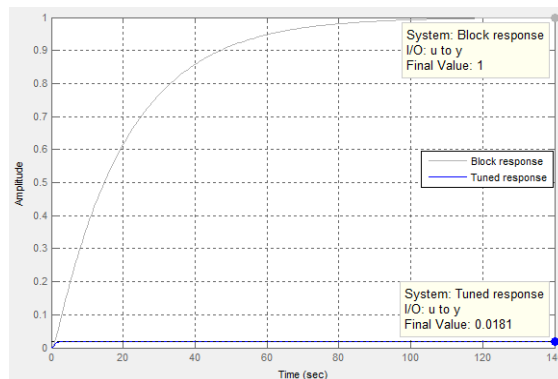

Fig. 4c. Step disturbance rejection of C

Gain and phase margins are common terms to describe how stable a system is and the behavior of the system at high frequencies. Gain and phase margins are used more because they are simple and ideal measurements of stability. Gain margin (GM) is the reciprocal of the magnitude when the phase of the open-loop transfer function crosses -180. Good value of GM > 5dB and for high robustness GM ≥ 20dB. Phase margin (PM) is the difference between the phase angle minus 180 when the magnitude of the open-loop transfer function crosses 0dB. Good value of PM ≥ 40degrees. The robustness bound shown in Fig. 5 illustrates the disturbance rejection capability of the system. For example, Figs. 6a and 6b show Bode plot generated using MATLAB software. In Fig. 6a, the phase of the open-loop transfer function crosses -180, at which point the gain margin is greater than zero (GM>0), therefore the system is stable. However, the phase of the open-loop transfer function did not cross -180 line in Fig. 6b, hence gain margin is less than zero (GM<0) therefore, the system is unstable. In order to achieve a robust system design, it is not enough to say that the system is stable but the value of the GM and the gain values at high frequencies will determine if the system is robust. In Fig. 6a, the GM=40.1dB at 34.2rad/sec frequency for the tuned response with PM=60degrees at 2.4rad/sec frequency the system can be said to be robust but the steady state error must be evaluated and must be zero in order to draw final conclusion. For the block response in Fig. 6b the PM is 90dB at 0.0503rad/sec frequency i.e. the magnitude of the open-loop transfer function crossed zero at very low frequency of 0.0503rad/sec and may not be considered. To find the steady state response to a sinusoidal input and replacing s with jω (i.e. s = jω):

Magnitude:  $\left| \frac{A_{out}}{A_{in}} \right| = |G(j\omega)|$

$\Phi \approx \angle G(j\omega)$

Where

$A_{out}$  is the output signal amplitude  
 $A_{in}$  is the input signal amplitude

Phase Angle  $\Phi$  is the phase shift introduced by the system

$|G(j\omega)|_{dB} = 20 \log |G(j\omega)|$

$\Phi_{deg} = \frac{180}{\pi} \Phi_{rad}$

**4.3 Performance Robustness**

The performance of a controlled system is usually evaluated from the step reference tracking response as shown in Fig. 7 and also from the Bode plot. The control design process begins by defining the performance requirements of the system. Control system performance is often measured by applying a step function as the set point command variable, and then measuring the response of the plant variable. Commonly, the response is quantified by measuring defined step reference tracking trajectory characteristics such as rise time, overshoot, settling time and steady state error. The rise time is customarily defined as the time required for the response to a unit step input to rise from 10% to 90% of its final value or steady-state. For underdamped second-order system, the 0% to 100% rise time is normally used. For overdamped systems, the 10% to 90% rise time is common. Percent Overshoot, %OS is the

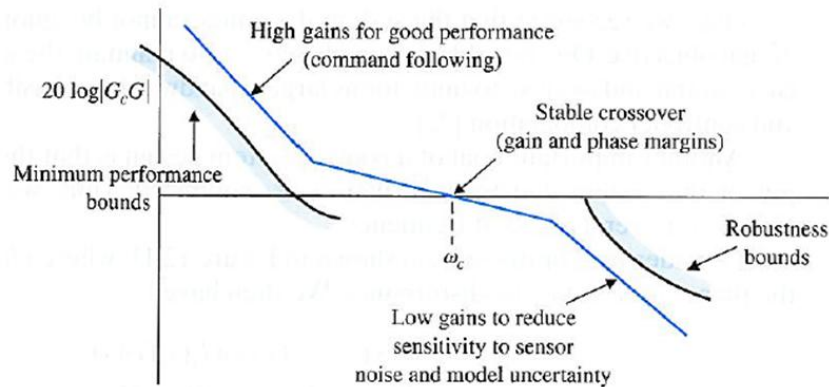

**Fig. 5. Demonstration of system behavior on Bode plot [18]**



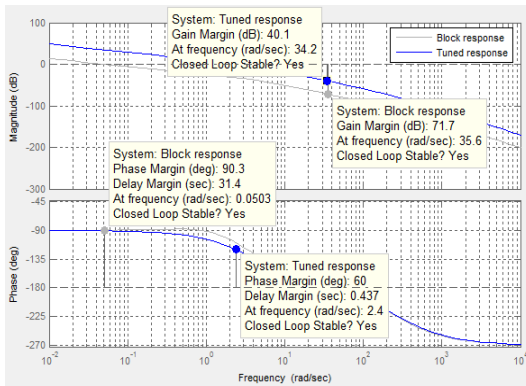

Fig. 6a. Bode plot for a stable system

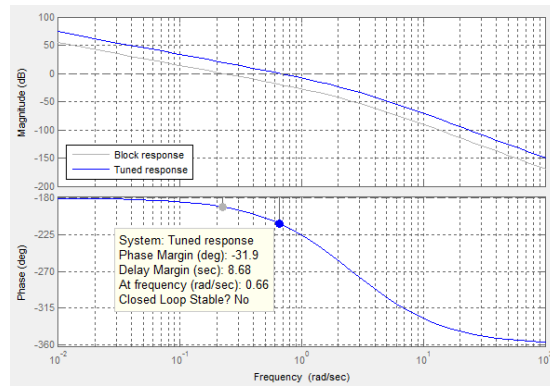

Fig. 6b. Bode plot for an unstable system

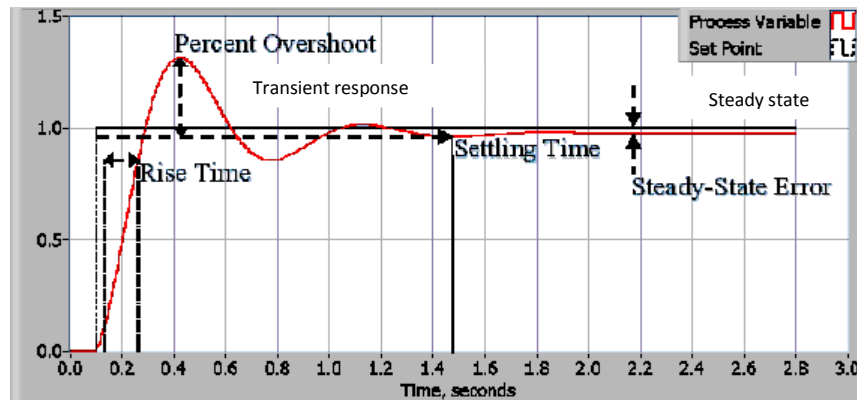

Fig. 7. Step reference tracking response of a PID closed-loop control system

amount that the underdamped step response overshoots the steady state, final, or value at the peak time, expressed as a percentage of the steady-state value. Settling Time is the time required for the system output to settle within a certain percentage of the input amplitude. Steady-State Error is the difference between the input and output of a system after the natural response has decayed to zero [2]. The steady state error can be observed on the step reference tracking response as shown in Fig. 7 but not always the exact value. The step disturbance rejection response shows the exact value of the steady state error.

Since the control system operates in real environment, there are disturbances that affect the plant variable and the output measurement. The measure of how well the control system is able to overcome the effects of disturbances is referred to as the disturbance rejection of the controlled system. In the same vein, the measure of how fast the control system is able to overcome or reject the effects of disturbances

can be referred to as the disturbance rejection settling time of the controlled system.

### 5. CONCLUSION

Robustness analysis of a closed-loop controller for a robot manipulator was studied in this work. Many robot manipulators have been designed and built without considering the uncertainties that exist in real environments. This work presents the robustness analysis as a vital requirement in the design of all robot manipulators so that they can operate and complete tasks in the presence of significant uncertainties. A control system is robust when it can maintain low sensitivity, zero steady state error, and stable over the range of parameter variations and its performance continues to meet the specifications of the designer in the presence of uncertainties. Robustness and optimization of the robot manipulator and other control systems can be achieved using the closed-loop control technique. Bode plot was used because it provides a clearer and simple means to evaluate

the performance and robustness behavior of the controlled system in frequency domain. It is easier to examine and understand the response of a control system in frequency domain than in time domain. The disturbance rejection and disturbance rejection settling time describe how well and fast the controlled system can overcome disturbances. Finally, the use of software tools such as MATLAB/SIMULINK provides a simpler and reliable means of studying, analyzing and designing a robust system. However, the use of the software tool requires basic knowledge of the control systems, design techniques and robustness analysis.

### COMPETING INTERESTS

Author has declared that no competing interests exist.

### REFERENCES

1. Romero G, Alcorta E, Lara D, Perez I, Betancourt R, Ocampo H. New method for tuning robust controllers applied to robot manipulators. *International Journal of Advanced Robotic Systems*. 2012; 9(210):1-8.
2. Dukkupati RV. Analysis of design of control system using MATLAB. New Age International (P) Limited Publishers, New Delhi; 2006.
3. Siqueira AAG, Terra MH. Neural Network-based H<sub>∞</sub> control for fully actuated and underactuated cooperative manipulators. *IEEE, Proceedings of the American control conference marriott marquis hotel at times square, New York City, USA*. 2007;3259-3264.
4. Nogueira SL, Pazelli TFPAT, Siqueira A AG, Terra MH. Experimental investigation on adaptive robust controller designs applied to constrained manipulators. *MDPI, Basel, Switzerland*. 2013; 13(4):5181-5204.
5. Corradini ML, Fossi V, Giantomassi A, Ippoliti G, Longhi S, Orlando G. Discrete time sliding mode control of robotic manipulators: Development and experimental validation. *Control Engineering Practice*. 2012;1-20.
6. Lara-Molina FA, Rosário JM, Dumur D, Wenger P. Robust generalized predictive control of the Orthoglide robot, industrial robot: An *International Journal*. 2014;41(3):275-285.
7. Agbaraji EC, Inyama HC. A survey of controller design methods for a robot manipulator in harsh environments. *European Journal of Engineering and Technology*. 2015;3(3):64-73.
8. Plooij M, Wolfslag W, Wisse M. Open loop stable control in repetitive manipulation tasks. *IEEE*; 2014.
9. Sano K, Kawai H, Murao T, Fujita M. Open-loop control for 2DOF robot manipulators with antagonistic Bi-articular muscles; 2012.
10. Fallahi M, Azadi S. A novel adaptive sliding mode control for DC motor. *International Journal of Advanced Engineering Applications*. 2001;4(3):19-27.
11. Faramarzi A, Sabahi K. Recurrent fuzzy neural network for DC motor control. Paper presented at 5<sup>th</sup> International Conference on Genetic and Evolutionary Computing (ICGEC). *IEEE*. 2011;93-96.
12. Farhan AS. Mechatronics design of motion systems; modeling, control and verification. *International Journal of Mechanical & Mechatronics Engineering IJMME-IJENS*. 2013;13(02):1-17.
13. Kumar RGV, Raja CVN. Comparison between FSC and PID controller for 5DOF robot arm. *International Journal of Emerging Trends in Electrical and Electronics (IJETEE – ISSN: 2320-9569)*. 2014;10(2):1-6.
14. Muhammad A. On replacing PID controller with ANN controller for DC motor position control. *International Journal of Research Studies in Computing*. 2013;2(1):21-29.
15. Sage HG, de Mathelin MF, Ostertag E. Robust control of robot manipulators: A survey. *Int. J. Control*. 1999;72(16):1498-1522.
16. Sreenatha AG, Makarand P. Fuzzy logic controller for position control of flexible structures. *Acta Astronaut Journal*. 2002;50(11):665–671.
17. Youns MD, Attya SM, Abdulla AI. Position control of robot arm using genetic algorithm based PID controller. *Al-Rafidain Engineering*. 2013;21(6):19-30.
18. Dorf RC, Bishop RH. *Modern control systems*. 11th ed. Pearson Prentice Hall; 2008.
19. D'Azzo JJ, Houpis CH, Sheldon SN. *Linear control system analysis and design with MATLAB*, CRC; 2003.
20. Siciliano B, Khatib O. *Springer handbook of robotics*. Springer-Verlag New York Inc; 2008.

21. Piltan F, Mirzaei M, Shahriari F, Nasari I, Emamzadeh S. Design baseline computed torque controller. *International Journal of Engineering (IJE)*. 2012;6:3.
22. Abdallah C, Dawson D, Dorato P, Jamshidi M. Survey of robust control for rigid robots. *IEEE Control Systems Magazines*. 1991;24-30.
23. Spong MW. On the robust control of robot manipulators. *IEEE Trans. on Automat. Contr.* 1992;37(11):1782-1786.
24. Ren X, Rad A, Lewis F. Neural network-based compensation control of robot manipulators with unknown dynamics. *American Control Conference. ACC'07*. 2007;13-18.
25. Okoro IO. *Introduction to MATLAB/SIMULINK for engineers and scientists*. 2<sup>nd</sup> ed. John Jacobs Classic Publishers Ltd., Enugu, Nigeria. 2008;216.

---

© 2015 Agbaraji; This is an Open Access article distributed under the terms of the Creative Commons Attribution License (<http://creativecommons.org/licenses/by/4.0>), which permits unrestricted use, distribution, and reproduction in any medium, provided the original work is properly cited.

*Peer-review history:*  
*The peer review history for this paper can be accessed here:*  
<http://sciencedomain.org/review-history/11910>